



Warning



- Ask a qualified installer or contractor to install this product. Do not try to install the product yourself. Improper installation can result in water or refrigerant leakage, electrical shock, fire or explosion.
- Use only those parts and accessories supplied or specified by Daikin. Ask a qualified installer or contractor to install those parts and accessories. Use of unauthorised parts and accessories or improper installation of parts and accessories can result in water or refrigerant leakage, electrical shock, fire or explosion.
- Read the user's manual carefully before using this product. The user's manual provides important safety instructions and warnings. Be sure to follow these instructions and warnings.

If you have any enquiries, please contact your local importer, distributor and/or retailer.

Cautions on product corrosion

1. Air conditioners should not be installed in areas where corrosive gases, such as acid gas or alkaline gas, are produced.
2. If the outdoor unit is to be installed close to the sea shore, direct exposure to the sea breeze should be avoided. If you need to install the outdoor unit close to the sea shore, contact your local distributor.



PCVMT1541 **apr**v



V R V IV

R-410A

Heat Pump 60 Hz

The Wise Choice for Modern Buildings

First launched in Japan in 1982, the Daikin VRV system has been embraced by world markets for over 30 years. Now, Daikin proudly introduces the new-generation VRV IV system.

VRV IV

INDEX

Main Features

P03

Outdoor Unit Lineup

P13

Indoor Unit Lineup

P14

Specifications

P29

Option List

P51

Control Systems

P57

Air Treatment Equipment Lineup

P69

 **Energy saving**

System **COP** up to **5.23** and VRT technology

 **Space saving**

Single outdoor units up to **22 HP** & triple outdoor units up to **66 HP**. Required space of installation saved up to **43%**

 **Comfortable airflow**

Humanized and comfortable airflow created by the dual sensors

 **High reliability**

More reliable and stable operation of the system ensured by various advanced features

* VRV is a trademark of Daikin Industries, Ltd.

Large Capacity & Compact Unit

Large capacity unit

A single **VRV IV** outdoor unit (RHXYQ-A) capacity ranges from 8 HP to 22 HP in increment of 2 HP, and the capacity of a triple outdoor unit system is up to 66 HP.



VRV III Single units: Up to 18 HP → **VRV IV** Single units: Up to 22 HP
VRV III Triple units: Up to 54 HP → **VRV IV** Triple units: Up to 66 HP

Compact & lightweight design

Highly-integrated Daikin **VRV IV** system (RHXYQ-A) offers compact outdoor units to achieve maximum utilization of scarce and expensive space in modern buildings.

VRV III 22 HP vs **VRV IV 22 HP**

Installation space: 1.68m ²	Installation space: 0.95m ²	43% reduce
Weight: 534kg	Weight: 317kg	41% reduce (217kg reduce)

Dimensions: VRV III (Width: 2,190 mm, Depth: 765 mm) vs VRV IV (Width: 1,240 mm, Depth: 765 mm)

More effective space in the building!

Service space for centralised installation (10F x 3,750 m²/F = 37,500 m², 2,000HP)

Service space for floor by floor installation (3,750 m²/F, 200HP/F)

Installation space for **VRV III** (304 m²) vs **VRV IV** (172 m²) → **43% less space!**

100HP A/C room: **VRV III** vs **VRV IV** → **45% less space!** (6,650 mm less)

Reducing constraints during carry-in

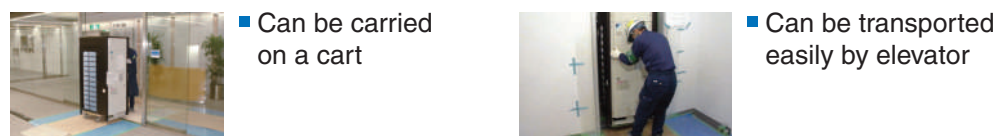

More Options for Installation Location

Long piping length

The long piping length provides more design flexibility, which can match even large-sized buildings.

- Max. actual piping length: **165 m**
- Max. equivalent piping length: **190 m**
- Max. total piping length: **1000 m**
- Max. level difference between the outdoor units and the indoor units: **90 m** *2 Available on request
- New** Max. level difference between the indoor units: **30 m** (15 m higher than VRV III)

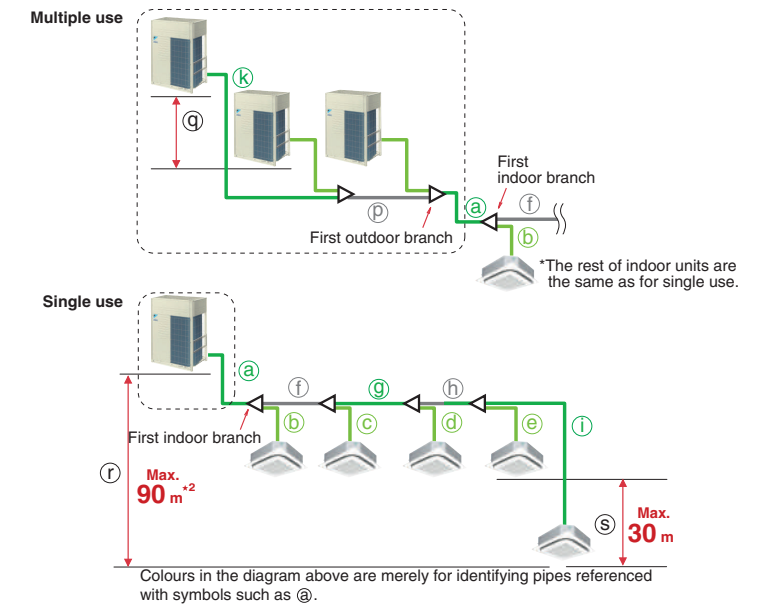

Maximum allowable piping length	Actual piping length		Example	Equivalent piping length
	Refrigerant piping length	Total piping length		
Between the first indoor branch and the farthest indoor unit	165 m	1000 m	a+f+g+h+i	190 m
	90 m*1		a+b+c+d+e+f+g+h+i	—
	10 m		k+p	13 m

Maximum allowable level difference	Level Difference		Example
	Between the outdoor units (Multiple use)	Between the indoor units	
Between the outdoor units and the indoor units	5 m	30 m	q
			s
	If the outdoor unit is above.	*2 Available on request 90 m	r
		*2 Available on request 90 m	r

*1. No special requirements up to 40 m. The maximum actual piping length can be 90 m, depending on conditions. Various conditions and requirements have to be met to allow utilisation of 90 m piping length. Be sure to refer to the Engineering Data Book for details of these conditions and requirements.
 *2. Level differences above 50 m when the outdoor unit is above the indoor unit and 40 m when the outdoor unit is below the indoor unit are not supported by default but are available on request. Refer to the Engineering Data Book and contact your local dealer for more information.

High external static pressure

VRV IV outdoor unit (RHXYQ-A) has been achieved high external static pressure up to 81 Pa, ensuring the efficient heat dissipation and stable operation of equipment in either hierarchical or intensive arrangement.



Energy Saving

Higher COP

It has become essential for air conditioning manufacturers to develop systems that provide high energy savings. We at Daikin have made great efforts in this field, and the **VRV IV** system delivers highly efficient performance, contributing to high energy savings.

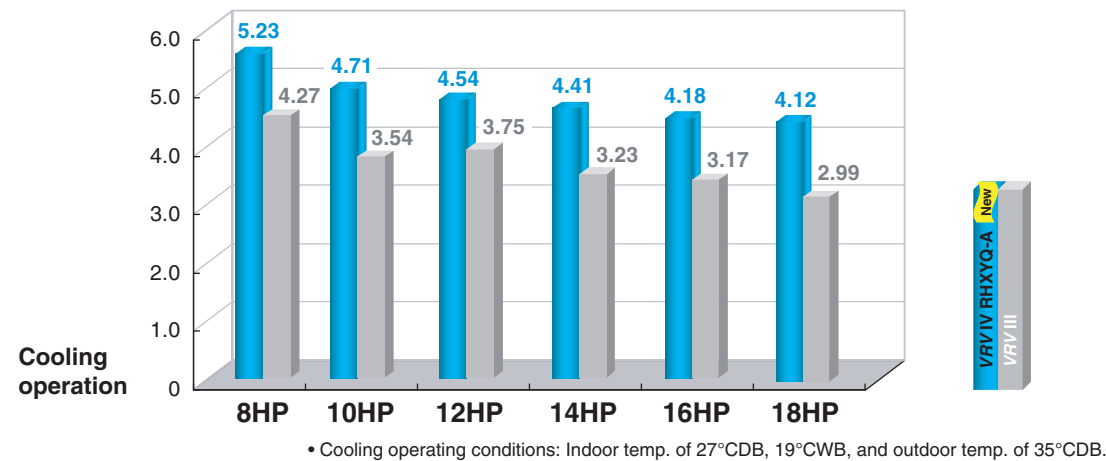

Advanced Technologies Achieve Excellent Performance

High-efficiency DC Inverter Scroll Compressor

Daikin **VRV IV** system adopts high-efficiency DC inverter hermetic scroll compressor with high-pressure and low-pressure chambers, which can dramatically enhance compression efficiency by making full use of the compression chamber area in compressor.

Superior metal scroll

Daikin has developed the superior metal scroll, whose pressure resistance is enhanced to 2.4 times of that of previous one, with the same processing technology used to the V-type engine in F1 racing car. The chamber volume is increased to 1.5 times of that of previous one through increasing scroll height by about 20% and effectively reducing the thickness of scroll wall, which can significantly enhance the compression amount of refrigerant and form an improved compressor structure with large capacity in a relatively slim body.

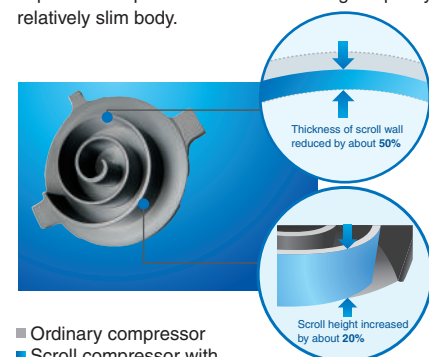

- Ordinary compressor
- Scroll compressor with high-pressure and low-pressure chambers

9-groove stator with concentrated coils

It can effectively improve the operation efficiency at partial load. At the same time, 9 rolled-up grooves are arranged independently, which not only further enhances the motor torque, but also prevents invalid heat conduction.

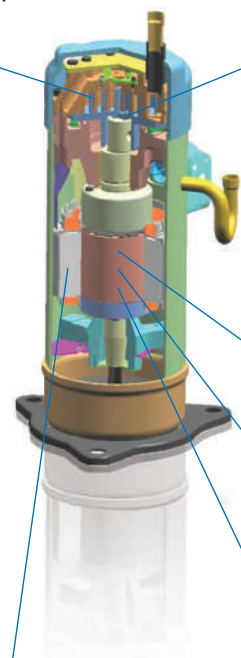

Differential pressure oil film hybrid technology

Oil film is generated by differential pressure between contact surfaces of fixed scroll to reduce friction, operating noise and mechanical loss effectively, which makes more stable operation and longer service life.

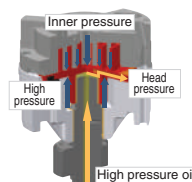

Sensorless technology

Motor speed can be detected without probes, effectively avoiding false output and multiple outputs.

Sine wave DC inverter technology

DC inverter outputs smooth sine wave, improving the operation efficiency of motor.

6-pole neodymium magnet motor

It can suppress the rotary vibration, achieving the better quiet effect.



Integrated 4-side heat exchanger

An advanced and efficient heat exchanger ensures the high efficiency and energy saving of Daikin **VRV IV** system. Effective heat exchange area of a **VRV IV** heat exchanger module is over 200 m², **2.7** times of that of **VRV III** system.

- Takes full advantage of the corner space, maximising the heat exchanger area and improving heat exchange efficiency.
- Takes full advantage of the unit height space, maximising the heat exchanger area and improving heat exchange efficiency.
- Reduces the solder joints significantly, ensuring more stable operation of outdoor unit.

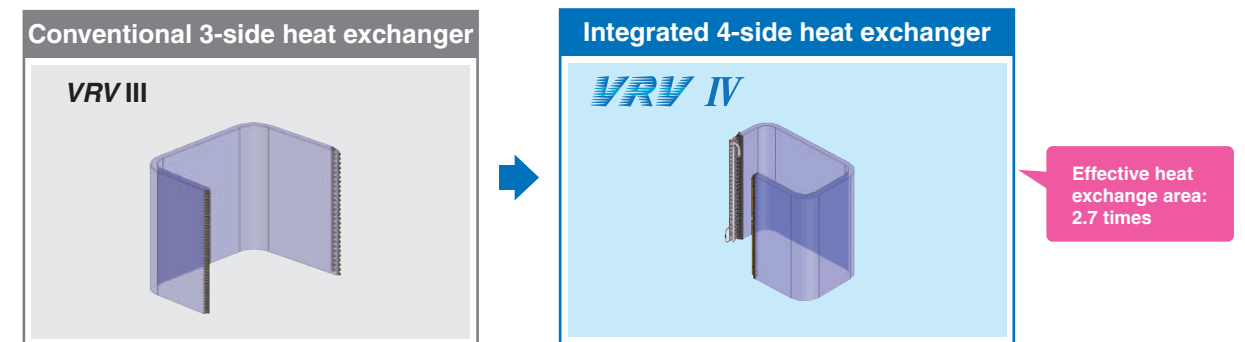

3-row heat exchanger and small diameter copper tube

Daikin has adopted 3-row copper tubes with small diameter (7 mm) in the new refrigerant piping, and the optimal design increases the effective heat exchange area, significantly enhancing the heat exchange efficiency and reducing the refrigerant charge for the system.

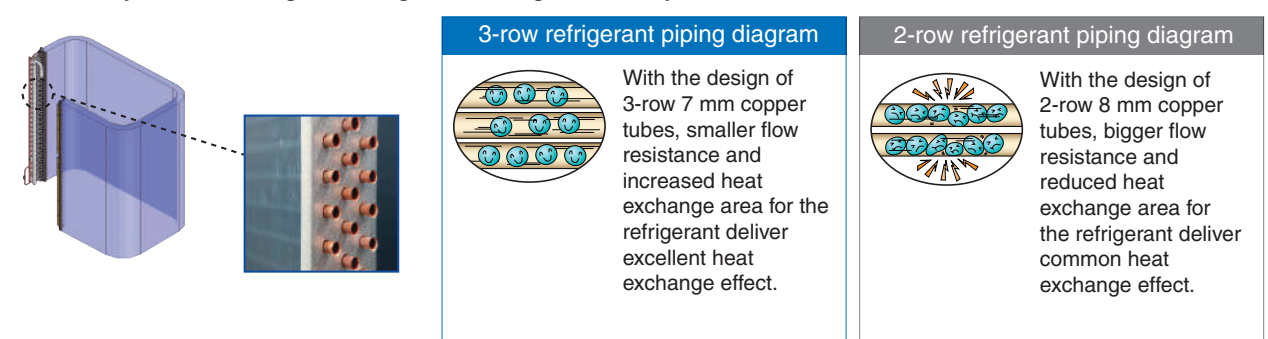

Optimally designed copper tube female thread

Daikin developed the best suited female thread for the unique piping structure of **VRV IV** system, which optimizes the turbulence of the refrigerant flow, and improves heat exchange efficiency.

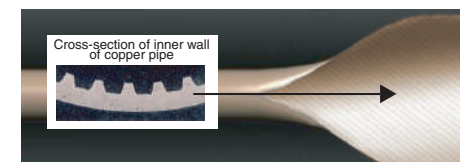

State - of - the - Art energy Saving Technology for VRV System

Customise your VRV system for optimal annual efficiency

The new **VRV IV** system now features VRT technology. VRT automatically adjusts refrigerant temperature to individual building and climate requirement, thus further improving annual energy efficiency and maintaining comfort. With this excellent technology, running costs are reduced.

How is energy reduced?

During cooling, the refrigerant evaporating temperature (T_e) is raised to minimise the difference with the condensing temperature. During heating, condensing temperature (T_c) is lowered to minimise the difference to the evaporating temperature. Compressors work less, and this reduces power consumption.

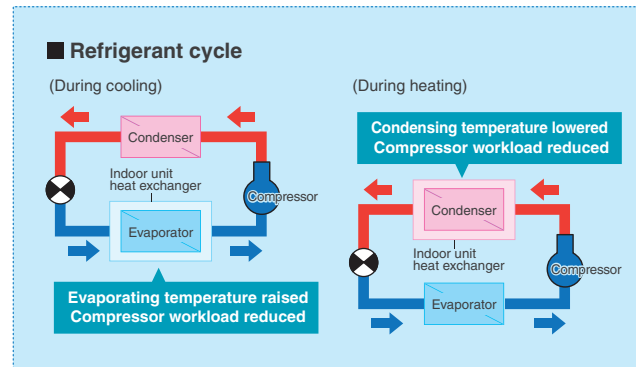

Typical changes in evaporating temperature and COP depending on changing indoor load

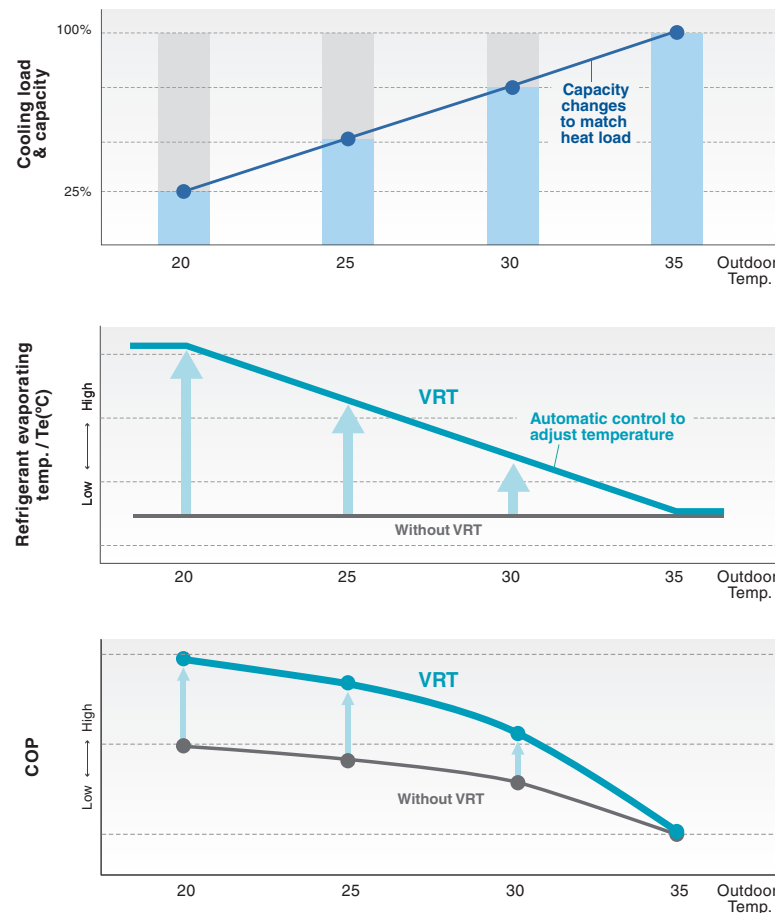

Required capacity changes as air conditioning load changes according to outdoor temperature.

In case of fixed evaporating temperature, excessive cooling, thermo on-off loss, and other inefficiencies occur.

Automatic control adjusts evaporating temperature to heat load change.

Energy efficiency is improved without sacrificing comfort.

Fine control to match user preference available through mode selection

Basic mode is selected to maintain optimal comfort. VRT is selected to save energy and prevent excessive cooling or heating.

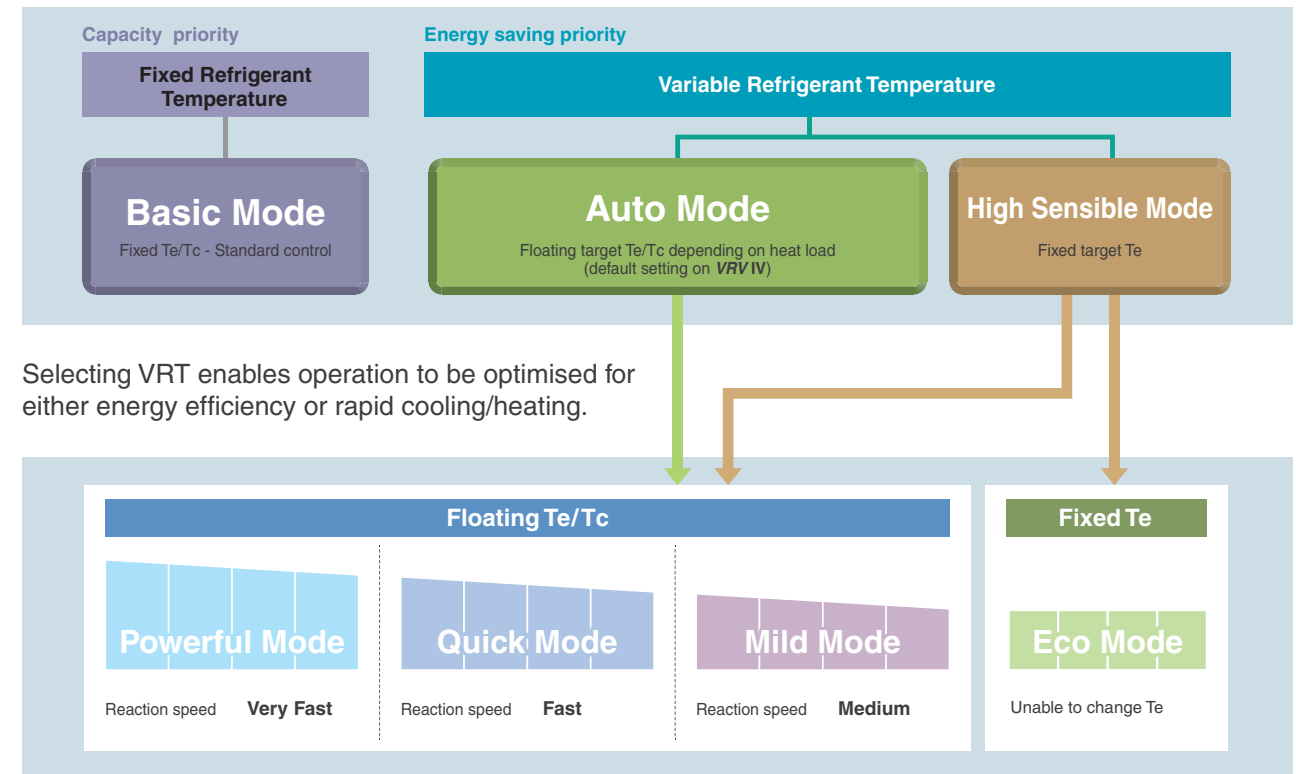

Selecting VRT enables operation to be optimised for either energy efficiency or rapid cooling/heating.

VRT offers quicker cool down to shorten uncomfortable pull down time.

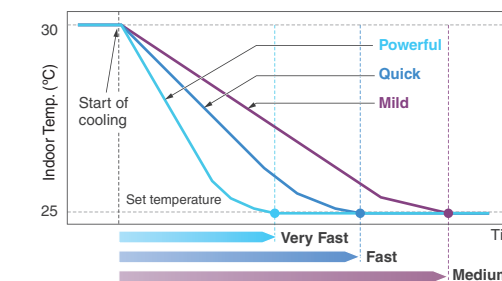

Powerful mode	<ul style="list-style-type: none"> Can boost capacity above 100% if needed. The refrigerant temperature can go lower in cooling (higher in heating) than the set minimum (maximum in heating). Gives priority to very fast reaction speed. The refrigerant temperature goes down (or up in heating) fast to keep the room setpoint stable.
Quick mode	<ul style="list-style-type: none"> Gives priority to fast reaction speed. The refrigerant temperature goes down (or up in heating) fast to keep the room setpoint stable.
Mild mode	<ul style="list-style-type: none"> Gives priority to efficiency. The refrigerant temperature goes down (or up in heating) gradually giving priority to the efficiency of the system instead of the reaction speed.

Recommended for use in these situations

Cooling only regions having differences in daily temperature.

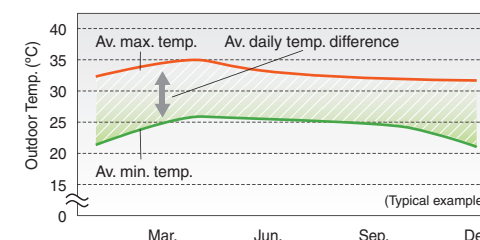

VRT is particularly effective at night when temperatures are low.

Cooling/heating regions having periods of mild outdoor temperatures.

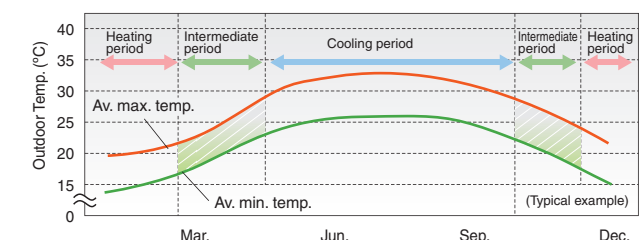

VRT is particularly effective during the intermediate periods.

Round Flow with Sensing Cassette Type



Comfort and Energy saving preventing over Cooling / Heating ^{*1,2} (Auto airflow direction mode + Auto airflow rate mode)

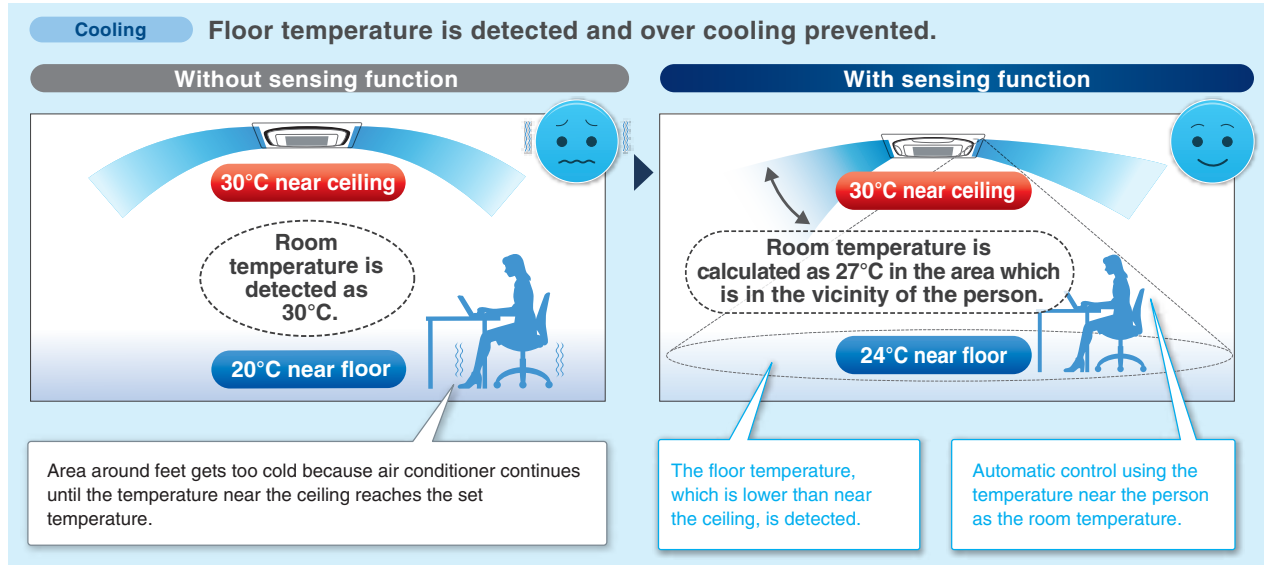

Energy savings The temperature near the person is automatically calculated by detecting the temperature of the floor. Energy is saved, because the area around the feet does not get too cold.

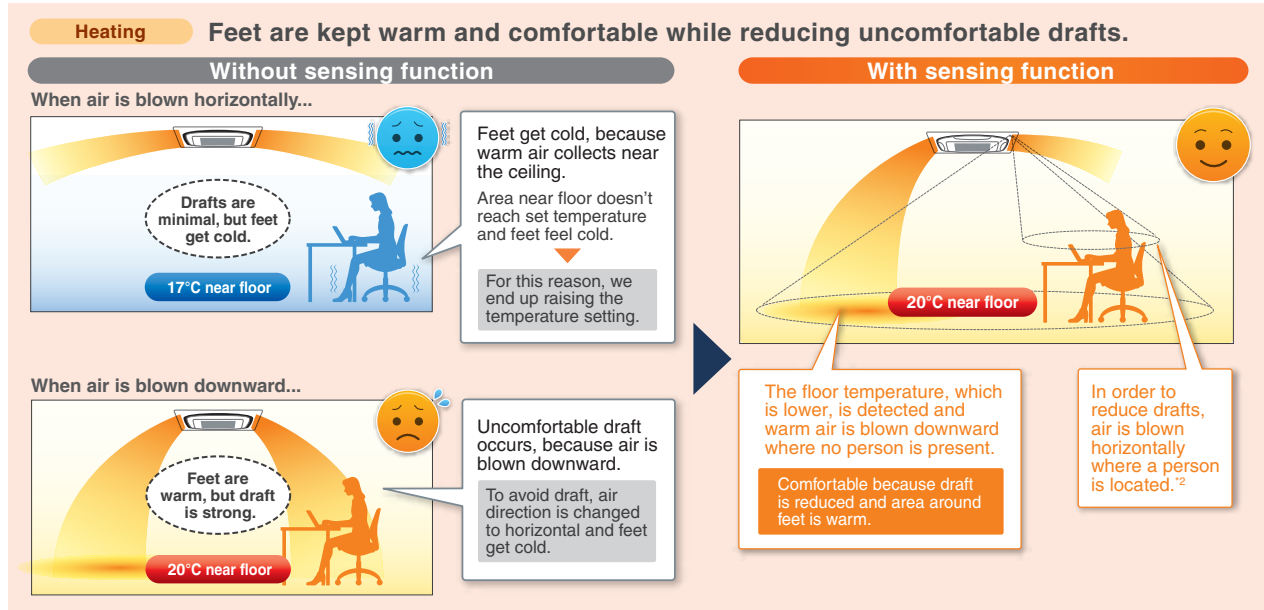

Energy savings The tendency of people to raise the temperature too much is prevented, because you are warmed up from the feet.

To increase comfort, Auto airflow rate mode controls the airflow in accordance with the difference between floor and ceiling temperatures.

When there is a large difference between the ceiling and floor temperatures, the airflow rate is automatically increased. When the difference becomes small, the airflow rate is automatically reduced.

^{*1} Both airflow direction and airflow rate should be set to Auto.
^{*2} Draft prevention function is set OFF in the initial setting.

Draft prevention function (default: OFF) ^{*1,2} (Auto airflow direction mode)

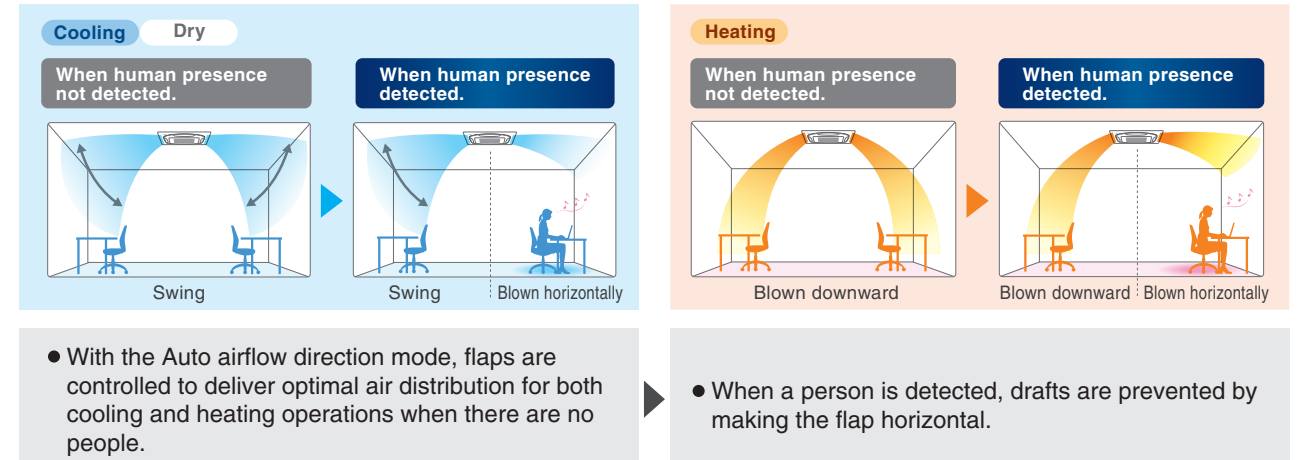

- With the Auto airflow direction mode, flaps are controlled to deliver optimal air distribution for both cooling and heating operations when there are no people.
- When a person is detected, drafts are prevented by making the flap horizontal.

^{*1} Airflow direction should be set to Auto.
^{*2} Draft prevention function is OFF in the initial setting. It can be set ON using the remote controller.

Quiet Operation

Quiet operation function creating an enjoyable serene ambience

Outdoor units adopt advanced large airflow, high static pressure and quiet technology & nighttime quiet operation technology, making the system operate in an efficient and quiet way.

Large airflow, high static pressure and quiet technology

Without increasing operation sound, advanced analytic technologies are utilized to optimise fan design and increase airflow rate and external static pressure.

Nighttime quiet operation function

Outdoor PC board automatically memorises the time when the peak outdoor temperature appears. It will enable quiet operation mode after 8 h^{*1}, and return to normal mode after it keeps for 9 h^{*2}.

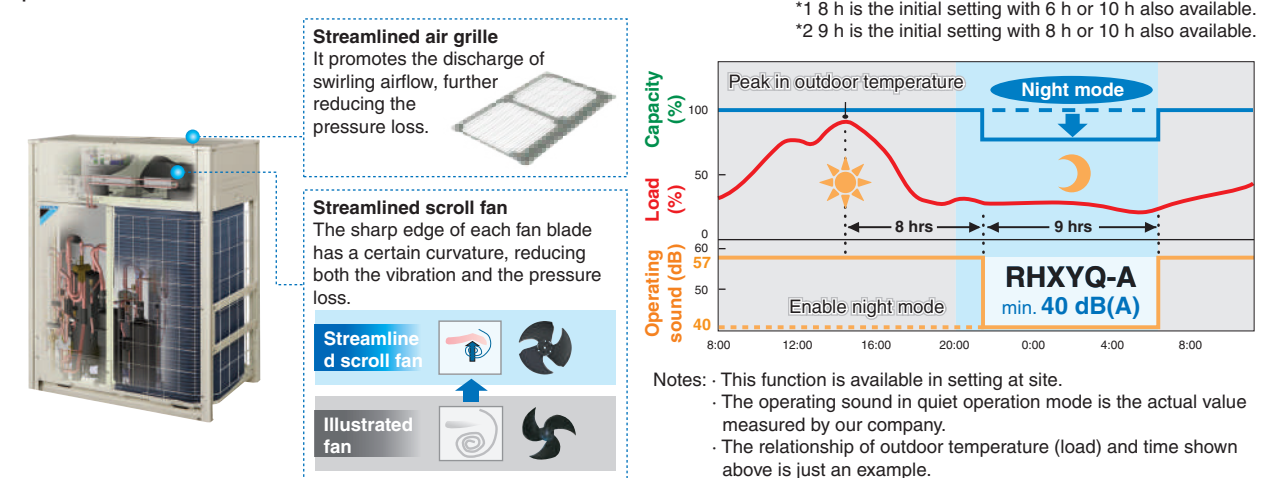

Various Advanced Control Main PC Board

Intelligent control main PC board

New generation intelligent control main PC board
Daikin's new intelligent control main PC board is highly integrated with 50% reduction in area and lower failure rate.

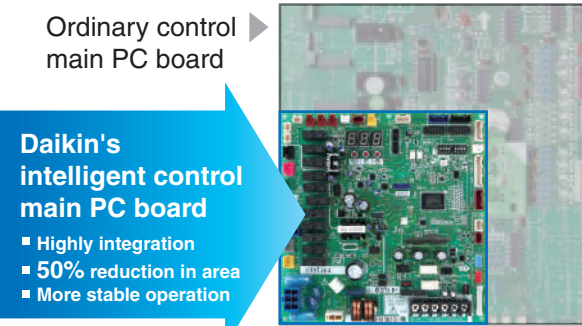

- Daikin's intelligent control main PC board**
- Highly integration
 - 50% reduction in area
 - More stable operation

SMT* packaging technology

- SMT packaging technology adopted by the whole computer control panel improves the anti-clutter performance.
- Protects your computer boards from the adverse effect of sandy and humid weather.

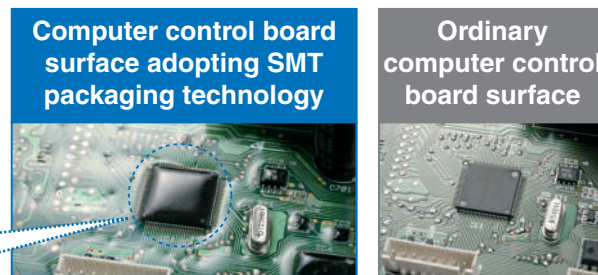
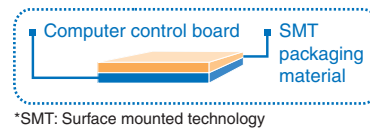

Master inverter control main PC board

Daikin **VRV IV** system utilizes all inverter technology which can control the compressor to realise the high-efficiency stepless linear frequency change through master inverter control main PC board in response to the actual demand for air conditioning capacity, thus achieving energy-efficient operation.

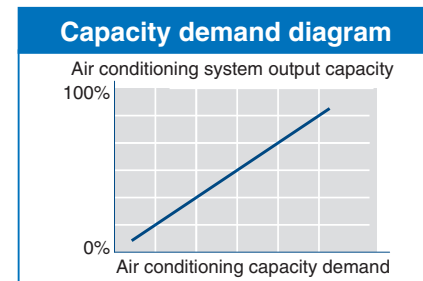

Chip liquid-cooled isothermal technology

Daikin **VRV IV** system adopts unique chip liquid-cooled isothermal technology which cools the main PC board with low temperature refrigerant and takes away large amount of heat emitted by main PC board, not only facilitating the outdoor unit downsizing, but also securing the stable operation of system.

Chip liquid-cooled isothermal technology can further enhance the system cooling efficiency by connecting main PC board with high-performance heat conductive rubber.

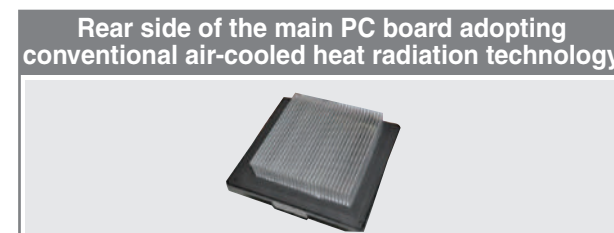
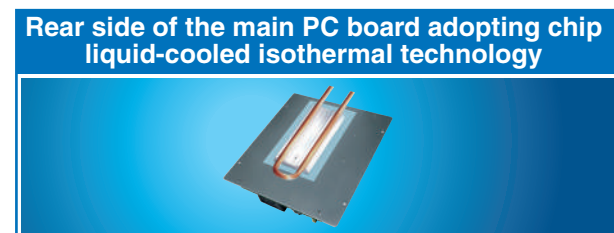

Double Backup Operation Functions

Daikin **VRV IV** system boasts double backup operation functions, which can secure the use of air conditioners in this area to the greatest extent by emergently enabling double backup operation functions even if failure occurs in a set of air conditioning equipment.

Unit backup operation function

If malfunction occurs in an outdoor unit...

Emergency operation can be conveniently set and enabled by the remote controller for indoor unit (for systems composed of two or more outdoor units).



Compressor backup operation function

If malfunction occurs in a compressor...

Emergency operation can be easily set and enabled by the outdoor unit (for a single outdoor unit system).



More Accurate Test Operation and Stable System

Efficient automatic test operation

Daikin **VRV IV** system incorporates the humanized and efficient test operation function, not only greatly accelerating the installation process, but effectively improving the field setting quality as well.

- Automatically checks the wirings between outdoor units and indoor units to confirm whether there is a defective wiring.
- Confirms and corrects the actual piping length.
- Automatically checks whether the refrigerant amount charged in the system is in the proper range according to the configurations of indoor and outdoor units and refrigerant piping length etc..



Accurate automatic refrigerant charge

Daikin **VRV IV** system can automatically estimate the required refrigerant charging amount, detect it through various sensors and adjust it to the most appropriate level for ensuring stable operation only after the installer simply pressing the automatic refrigerant charging button, thus eliminating the trouble of measuring the piping length and manually calculating the refrigerant charging amount.

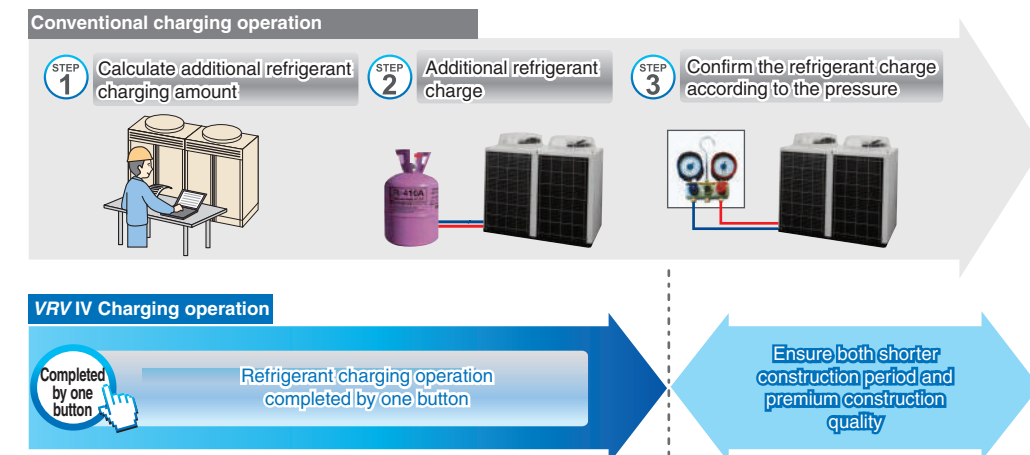

Note: Please refer to the Installation Manual for details.

Outdoor units

The outdoor unit capacity is up to 66 HP in increment of 2 HP.

- VRV IV outdoor unit (RHXYQ-A) offers a higher capacity of up to 66 HP, responding to the needs of large-sized building.
- The single outdoor unit has only 2 different shapes and dimensions, not only simplifying the design process, but also bringing the system flexibility to a new level.
- With the outdoor unit (RHXYQ-A) capacity increased in increment of 2 HP, customers' needs can be precisely met.
- New** Outdoor units can be selected from 3 series with different power supply.
 RHXYQ-AYL: 3-phase 4-wire system, 380 V, 60 Hz
 RHXYQ-ATL: 3-phase 3-wire system, 220 V, 60 Hz
 RXYQ-TYDN: 3-phase 3-wire system, 460 V, 60 Hz

RHXYQ-A 8, 10, 12 HP



RHXYQ8AYL/TL
RHXYQ10AYL/TL
RHXYQ12AYL/TL

14, 16 18, 20, 22 HP



RHXYQ14AYL/TL
RHXYQ16AYL/TL
RHXYQ18AYL/TL
RHXYQ20AYL/TL
RHXYQ22AYL/TL

24 HP



RHXYQ24AYL/TL

26, 28, 30, 32, 34 HP



RHXYQ26AYL/TL
RHXYQ28AYL/TL
RHXYQ30AYL/TL
RHXYQ32AYL/TL
RHXYQ34AYL/TL

36, 38, 40, 42, 44 HP



RHXYQ36AYL/TL
RHXYQ38AYL/TL
RHXYQ40AYL/TL
RHXYQ42AYL/TL
RHXYQ44AYL/TL

46, 48, 50, 52, 54, 56 HP



RHXYQ46AYL/TL
RHXYQ48AYL/TL
RHXYQ50AYL/TL
RHXYQ52AYL/TL
RHXYQ54AYL/TL
RHXYQ56AYL/TL

58, 60, 62, 64, 66 HP



RHXYQ58AYL/TL
RHXYQ60AYL/TL
RHXYQ62AYL/TL
RHXYQ64AYL/TL
RHXYQ66AYL/TL

RXYQ-T

7.5 HP



RXYQ72TYDN

10, 12.5, 15, 17.5 HP



RXYQ96TYDN
RXYQ120TYDN
RXYQ144TYDN
RXYQ168TYDN

20 HP



RXYQ192TYDN

22.5, 25, 27.5, 30, 32.5, 35 HP



RXYQ216TYDN
RXYQ240TYDN
RXYQ264TYDN
RXYQ288TYDN
RXYQ312TYDN
RXYQ336TYDN

37.5, 40, 42.5, 45, 47.5, 50, 52.5 HP



RXYQ360TYDN
RXYQ384TYDN
RXYQ408TYDN
RXYQ432TYDN
RXYQ456TYDN
RXYQ480TYDN
RXYQ504TYDN

* Refer to page 37-38 for combination details.

Indoor units

Wide range of indoor units includes 14 types and 90 models

Daikin's indoor unit system offers a large number of connectable indoor units—64! Furthermore, our wide range of indoor units includes 14 types and 90 models to meet the needs of customers.

Type	Model Name	Capacity Range (HP)	Capacity Index																	
			20	25	32	36	40	50	56	63	71	80	90	100	112	125	140	200	250	
Ceiling Mounted Cassette (Round Flow with Sensing)	New FXFSQ-AVE		●	●	●	●	●	●	●	●	●	●	●	●	●	●	●	●	●	
Ceiling Mounted Cassette (Round Flow)	New FXFQ-AVE		●	●	●	●	●	●	●	●	●	●	●	●	●	●	●	●	●	
Ceiling Mounted Cassette (Compact Multi Flow)	FXZQ-MVE		●	●	●	●	●	●	●	●	●	●	●	●	●	●	●	●	●	
Ceiling Mounted Cassette (Double Flow)	FXCQ-MVE		●	●	●	●	●	●	●	●	●	●	●	●	●	●	●	●	●	
Ceiling Mounted Cassette (Single Flow)	New FXEQ-AVE		●	●	●	●	●	●	●	●	●	●	●	●	●	●	●	●	●	
Slim Ceiling Mounted Duct	FXDQ-PBVE (with drain pump)		●	●	●	●	●	●	●	●	●	●	●	●	●	●	●	●	●	
	FXDQ-PBVET (without drain pump) (700 mm width type)		●	●	●	●	●	●	●	●	●	●	●	●	●	●	●	●	●	
	FXDQ-NBVE (with drain pump)		●	●	●	●	●	●	●	●	●	●	●	●	●	●	●	●	●	
	FXDQ-NBVET (without drain pump) (900/1,100 mm width type)		●	●	●	●	●	●	●	●	●	●	●	●	●	●	●	●	●	
Ceiling Mounted Duct	New FXMQ-AVE		●	●	●	●	●	●	●	●	●	●	●	●	●	●	●	●	●	
	FXMQ-PVE		●	●	●	●	●	●	●	●	●	●	●	●	●	●	●	●	●	
	FXMQ-MAVE		●	●	●	●	●	●	●	●	●	●	●	●	●	●	●	●	●	
4-Way Flow Ceiling Suspended	FXUQ-AVEB		●	●	●	●	●	●	●	●	●	●	●	●	●	●	●	●		
Ceiling Suspended	FXHQ-MAVE		●	●	●	●	●	●	●	●	●	●	●	●	●	●	●	●		
Wall Mounted	FXAQ-PVE		●	●	●	●	●	●	●	●	●	●	●	●	●	●	●	●		
Floor Standing	FXLQ-MAVE		●	●	●	●	●	●	●	●	●	●	●	●	●	●	●	●		
Concealed Floor Standing	FXNQ-MAVE		●	●	●	●	●	●	●	●	●	●	●	●	●	●	●	●		



Daikin offers a wide range of indoor units includes 14 types responding to variety of needs of our customers that require air-conditioning solutions.

Ceiling Mounted Cassette (Round Flow with Sensing) Type FXFSQ-AVE

New



Presence of people and floor temperature can be detected to provide comfort and energy savings



Ceiling Mounted Cassette (Double Flow) Type FXCQ-MVE



Thin, lightweight, and easy to install in narrow ceiling spaces



Ceiling Mounted Cassette (Round Flow) Type FXFQ-AVE

New



360° airflow improves temperature distribution and offers a comfortable living environment.



Ceiling Mounted Cassette (Single Flow) Type FXEQ-AVE

New



Slim design for flexible installation



Ceiling Mounted Cassette (Compact Multi Flow) Type FXZQ-MVE



Quiet, compact, and designed for user comfort



Slim Ceiling Mounted Duct Type FXDQ-PBVE(T)

FXDQ-NBVE(T)

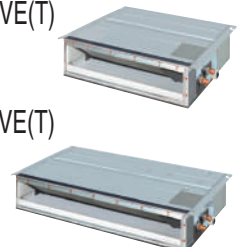

Slim design, quietness and static pressure switching



Ceiling Mounted Duct Type

New FXMQ-AVE
FXMQ-PVE



High external static pressure allows flexible installations



Wall Mounted Type FXAQ-PVE



Stylish flat panel design harmonised with your interior décor



Ceiling Mounted Duct Type FXMQ-MAVE



High external static pressure allows flexible installations



Floor Standing Type FXLQ-MAVE



Suitable for perimeter zone air conditioning



4-Way Flow Ceiling Suspended Type FXUQ-AVEB



This slim and stylish indoor unit achieves optimum air distribution, and can be installed without the need for ceiling cavity.



Concealed Floor Standing Type FXNQ-MAVE



Designed to be concealed in the perimeter skirting-wall



Ceiling Suspended Type FXHQ-MAVE



Slim body with quiet and wide airflow



Ceiling Mounted Cassette (Round Flow with Sensing) Type

New
 FXFSQ25A / FXFSQ32A / FXFSQ40A
 FXFSQ50A / FXFSQ63A / FXFSQ71A
 FXFSQ80A / FXFSQ90A / FXFSQ100A
 FXFSQ112A / FXFSQ125A



Presence of people and floor temperature can be detected to provide comfort and energy savings

Individual airflow direction control
 Thanks to the individual airflow direction control function, airflow direction can be individually adjusted for each air discharge outlet to prevent uncomfortable drafts and to deliver optimal air distribution.

Infrared presence sensor
 The sensor detects human presence and adjusts the airflow direction automatically to prevent drafts.

Ceiling height	2.7m	3.5m	4.0m
Detection range (diameter) ^{*1}	approx. 8.5m	approx. 11.5m	approx. 13.5m

*1. The infrared presence sensor detects 80 cm above the floor.

Infrared floor sensor
 The sensor detects the floor temperature and automatically adjusts operation of the indoor unit to reduce the temperature difference between the ceiling and the floor.

Ceiling height	2.7m	3.5m	4.0m
Detection range (diameter) ^{*2}	approx. 11m	approx. 14m	approx. 16m

*2. The infrared floor sensor detects at the floor surface.

Sensing sensor mode^{*3,4}

■ Sensing sensor low mode (default: OFF)

When there are no people in a room, the set temperature is shifted automatically.

The system automatically saves energy by detecting whether or not the room is occupied. The set temperature is shifted automatically if the room is unoccupied.

Operation is reduced in places where there are no people.

Example • Cooling setpoint: 26°C • Shift temperature: 1.0°C
 • Shift time: 30 min. • Limit cooling temperature: 30°C

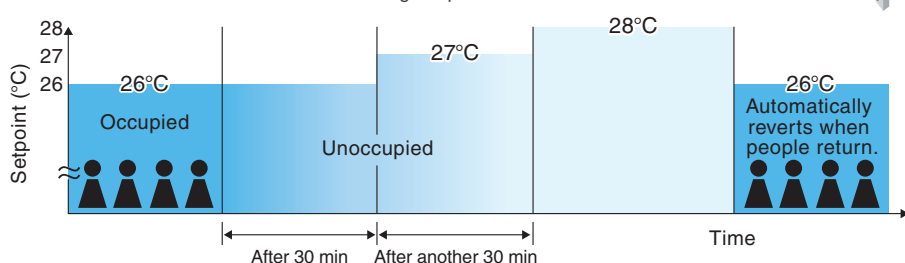

If people do not return, the air conditioner will raise the temperature 1°C every 30 minutes and then operate at 30°C.

*3. These functions are not available when using the group control system.
 *4. User can set these functions with remote controller.

■ Individual airflow direction control

■ Individual airflow setting

Airflow direction of each of the four air outlets can be controlled individually.

(Positions 0 to 4, Swing, Blocked, and No individual setting are selectable.)



Individual setting list

Outletmark	Air direc.	Indiv.
<input type="checkbox"/>	blocked	ON
<input type="checkbox"/>	Auto	OFF
<input type="checkbox"/>	Position 2	ON
<input type="checkbox"/>	Swing	ON

Return

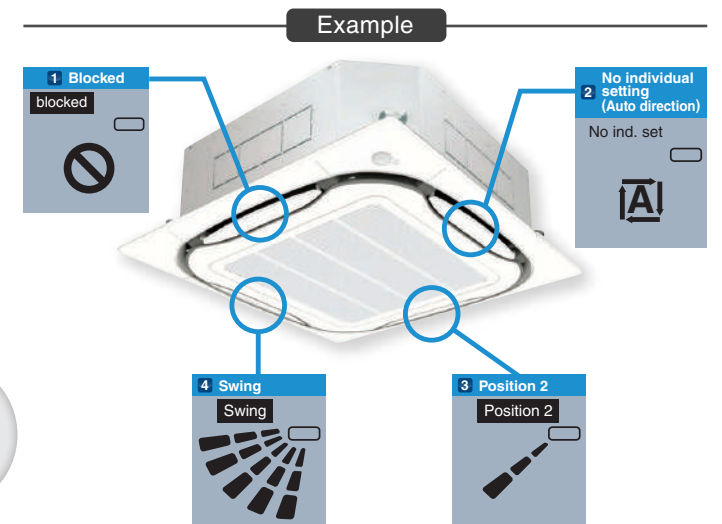
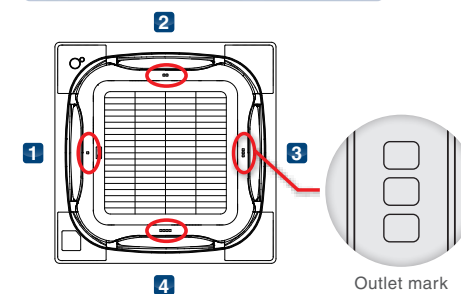

■ Airflow block function^{*1}

Total comfort by individual airflow direction control and “airflow block function”

The system automatically saves energy by detecting whether or not the room is occupied. The set temperature is shifted automatically if the room is unoccupied.

- Airflow block function prevents uncomfortable drafts by reducing air velocity. It can be set using the BRC1E62 remote controller. There is no need for sealing material of air discharge outlet (option).
- This function only works when all-round flow is used. It cannot be used when sealing material is used in the air discharge outlet (option).

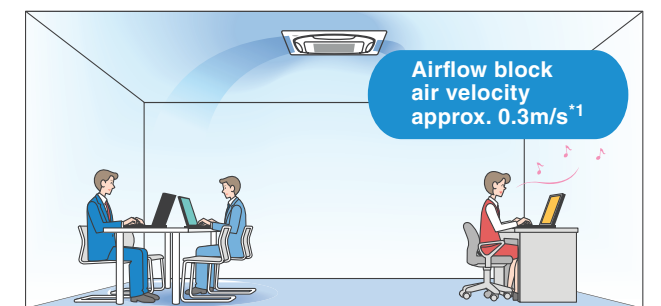

Airflow block function prevents uncomfortable drafts by reducing air velocity to approx. 0.3m/s.^{*2}

Easy setup with remote controller

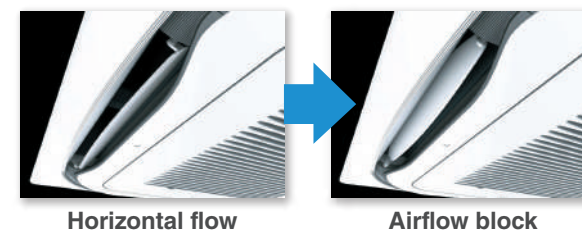

The airflow block function is useful when rearranging the room layout.

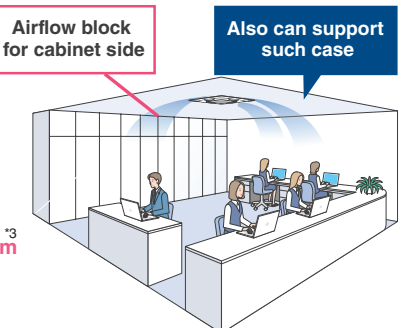
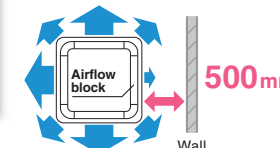

*1. Works in one direction only.
 *2. In case of FXFQ63S type (Data is based on Daikin research.) When using FXFQ80S type or higher, if the airflow rate is set to High, airflow will be on the high side. Under actual conditions, however, the airflow value may differ depending on the effect of surrounding conditions and the way in which the temperature was adjusted.
 *3. A gap of 1500 mm is required if the air block function is not used.

Ceiling Mounted Cassette (Round Flow) Type

New

FXFQ25A / FXFQ32A / FXFQ40A
FXFQ50A / FXFQ63A / FXFQ71A
FXFQ80A / FXFQ90A / FXFQ100A
FXFQ112A / FXFQ125A



360° airflow improves temperature distribution and offers a comfortable living environment.

- The Round Flow Ceiling Mounted Cassette type indoor unit creates a comfortable air conditioning environment with its 360° airflow.



4-way flow

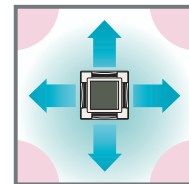

There are areas of uneven temperature.

Round Flow

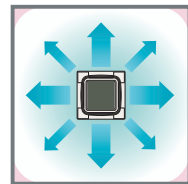

There are much fewer areas of uneven temperature.

- The slim body makes the height of suspended ceiling decreased.

FXFQ-A	25/32/40/50/63	71/80/90/100	112/125
Body height	204mm	246mm	288mm

- Low operation sound level (dB(A))

FXFQ-A	25/32	40	50	63	71/80	90/100	112/125
Sound level (H/M/L)	30/28/25	32/29/25	33/30/27	34/31/28	38/34/29	41/37/33	44/39/34

- Control of airflow rate can be selected from 3-step control.



Energy-saving operation

- DC fan motor is used to realize energy-saving operation.
 - The high-efficiency heat exchanger is used to improve heat exchange efficiency.
 - The dead spot* of airflow is eliminated.
- * With dead spots eliminated, the comfort level in the whole space is still achieved by properly increasing the set temperature (e.g. in cooling mode), thus effectively reducing energy consumption.

- The air filter has an anti-mould and antibacterial treatment that prevents the growth of mould generated from dust or moisture that may adhere to the filter.

- Drain pump is equipped as standard accessory with 850 mm lift.

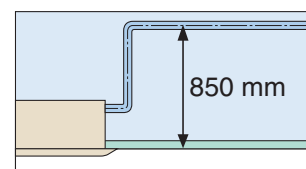

Ceiling Mounted Cassette (Compact Multi Flow) Type

FXZQ20M / FXZQ25M / FXZQ32M
FXZQ40M / FXZQ50M



Quiet, compact, and designed for user comfort

- Dimensions correspond with 600 mm × 600 mm architectural module ceiling design specifications.

- Low operation sound level

	(dB(A))			
FXZQ-M	20/25	32	40	50
Sound level (H/L)	32/29	33/29	36/30	41/34

- Comfortable airflow

- Wide discharge angle: 0° to 60°

- Auto swing

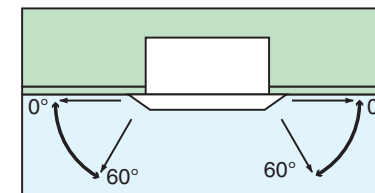

- Fixed angles: 5 levels

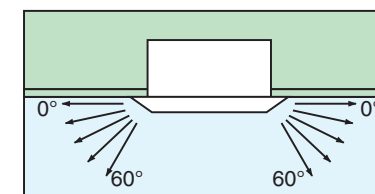

*Angles can be also set on site to prevent drafts (0°-35°) or soiling of the ceiling (25°-60°), other than standard setting (0°-60°).

- 2-, 3-, and 4-way airflow patterns are available, enabling installation in the corner of a room.

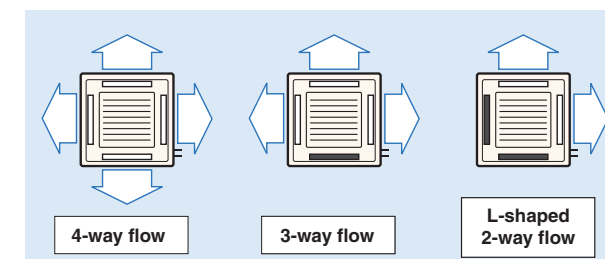

*For 3-way or 2-way flow installation, the sealing material for air discharge outlet (option) must be used to close each unused outlet.



- Drain pump is equipped as standard accessory with 750 mm lift.

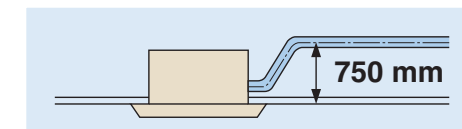

Ceiling Mounted Cassette (Double Flow) Type

FXCQ20M / FXCQ25M / FXCQ32M
FXCQ40M / FXCQ50M / FXCQ63M
FXCQ80M / FXCQ125M



Thin, lightweight, and easy to install in narrow ceiling spaces

- The thin unit (only 305 mm high) can be installed in a ceiling space as narrow as 350 mm. All models feature a compact design with a depth of only 600 mm.

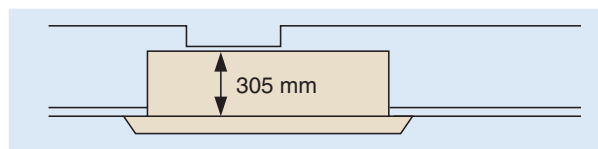

(When a high-efficiency filter is attached, the unit's height is 400 mm.)

- Low operation sound level (dB(A))

FXCQ-M	20	25/32	40/50	63	80	125
Sound level (H/L)	32/27	34/28	34/29	37/32	39/34	44/38

- Designed with higher airflow suitable for high ceiling application up to 3 metres.

- Providing 2 different settings of standard and ceiling soiling prevention, the auto swing mechanism realises even distribution of airflow and room temperature.

- Drain pump is equipped as standard accessory with 600 mm lift.

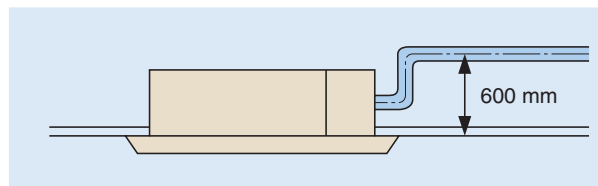

- Two types of optional high-efficiency filter are available (65% and 95%, colourimetric method).

- A long-life filter (maintenance free up to one year*) is equipped as standard accessory.

* 8 hr/day, 25 day/month. For dust concentration of 0.15 mg/m³

- Major maintenance work can be performed by removing the panel. A flat-type suction grille and a detachable blade make cleaning easy.

Ceiling Mounted Cassette (Single Flow) Type

New

FXEQ20A / FXEQ25A / FXEQ32A
FXEQ40A / FXEQ50A / FXEQ63A



Slim design for flexible installation

- The body features a compact design with a height of just 200 mm and depth 470 mm, making the installation possible in tight ceiling spaces.

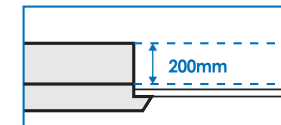

- The unique air discharge mode brings airflow all the way to the floor during heating operation, thus making the better heating effect.

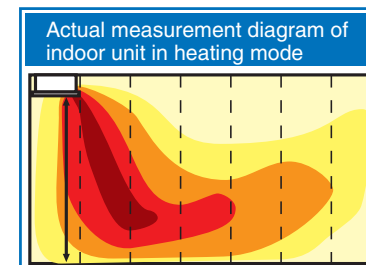

Note: The actual values measured by our company.

- The swinging of horizontal and vertical swing blades can be adjusted freely with the remote controller BRC1F61, providing 3D airflow to every corner of the room.

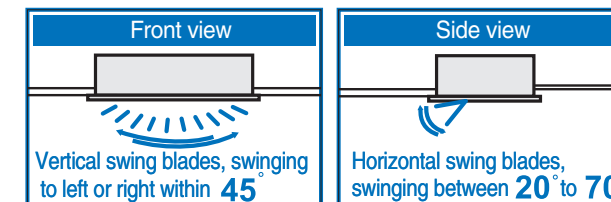

- DC motor is adopted both in the fan and drain pump of the indoor unit, not only enhancing the energy saving performance, but also reducing the operating sound and the vibration incurred to the unit.

- Control of airflow rate can be selected from 5-step control and quiet operation mode with the remote controller BRC1F61, which provides comfortable airflow.

- While creating a cozy indoor environment, the unit can prevent the suspended ceiling from being soiled by adjusting its louvre angle.

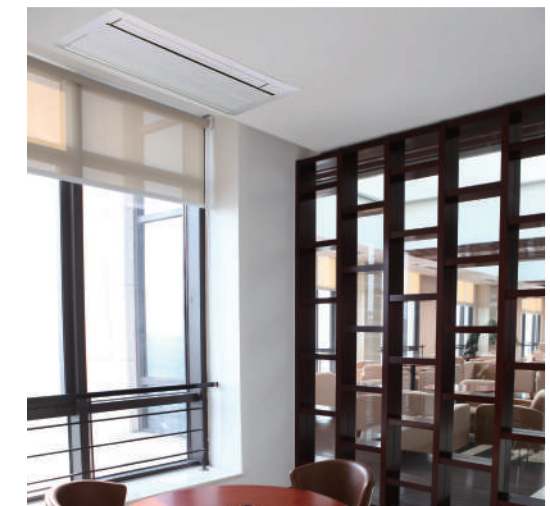

- The novel smooth panel design makes dust difficult to accumulate, thus causing the cleaning more conveniently.



- Drain pump is equipped as standard accessory with 850 mm lift.

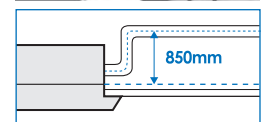

- The mould proof operation function can effectively suppress the propagation of mould in the heat exchanger of the indoor unit even in coast areas with high humidity.

- No service port is required during installation, and servicing of common parts such as the control box etc. can be performed easily only with the suction panel removed.

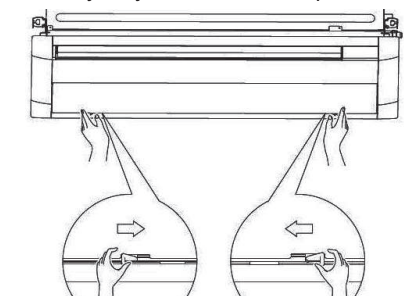

Slim Ceiling Mounted Duct Type

Slim design, quietness and static pressure switching

Suited to use in drop-ceilings!

FXDQ20PB / FXDQ25PB / FXDQ32PB

- Only 700 mm in width and 23 kg in weight, this model is suitable to install in limited spaces like drop-ceilings in hotels.

Great for hotel use!

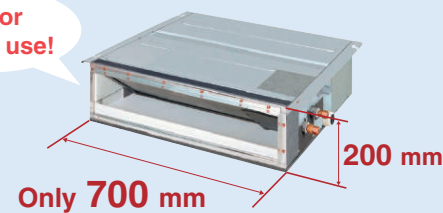

- Control of the airflow rate has been improved from 2-step to 3-step control.

● Low operation sound level

	(dB(A))				
FXDQ-PB/NB	20/25	32	40	50	63
Sound level (HH/H/L)	28/26/23	28/26/24	30/28/26	33/30/27	33/31/29

* The values of operation sound level represent those for rear-suction operation. Sound level values for bottom-suction operation can be obtained by adding 5 dB(A).
* Values are based on the following conditions:
FXDQ-PB: external static pressure of 10 Pa; FXDQ-NB: external static pressure of 15 Pa.

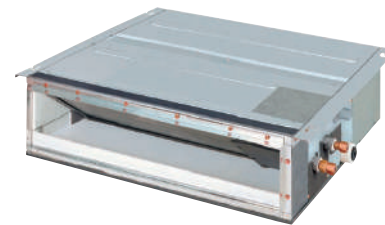

FXDQ40NB / FXDQ50NB / FXDQ63NB

- Only 200 mm in height, this model can be installed in rooms with as little as 240 mm in height for the ceiling space between the drop-ceiling and ceiling slab.

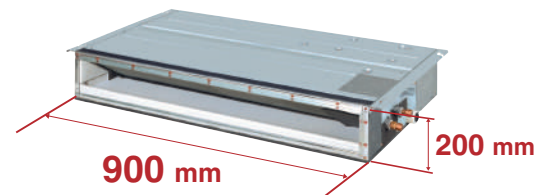

* 1,100 mm in width for the FXDQ63NB model.

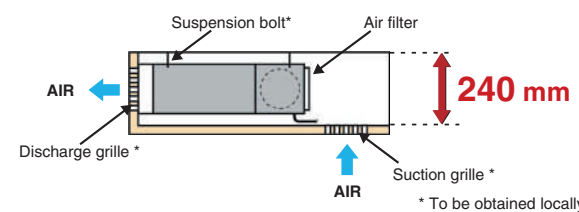

- External static pressure selectable by remote controller switching make this indoor unit a very comfortable and flexible model.

10 Pa-30 Pa/factory set: 10 Pa for FXDQ-PB models.
15 Pa-44 Pa/factory set: 15 Pa for FXDQ-NB models.

- FXDQ-PB and FXDQ-NB models are available in two types to suit different installation conditions.

FXDQ-PB/NBVE: with a drain pump (750 mm lift) as a standard accessory

FXDQ-PB/NBVET: without a drain pump

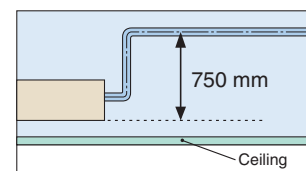

Ceiling Mounted Duct Type

**FXMQ20A / FXMQ25A / FXMQ32A
FXMQ36A / FXMQ40A / FXMQ50A
FXMQ56A / FXMQ63A / FXMQ80A
FXMQ100A / FXMQ125A
FXMQ140P**



High external static pressure allows flexible installations

- The external static pressure is up to 200 Pa for FXMQ-A, corresponding flexibly to various indoor space.

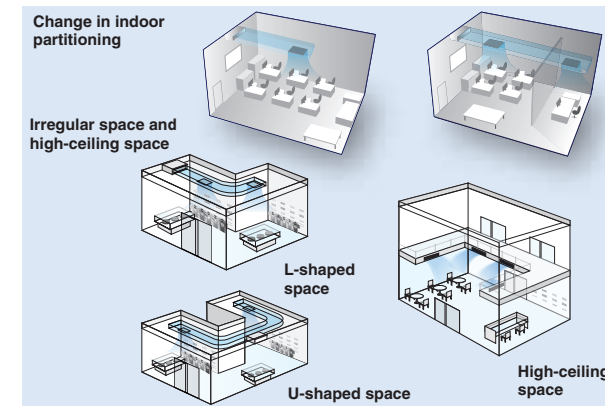

- Up to 14 levels of external static pressure for FXMQ-A can be set and adjusted directly with the remote controller, thus making the unit cope with different static pressure requirements with ease.

- A selection of air ports can be utilized to harmony with different decoration styles.

Examples



Note: The above air ports need to be purchased on site.

- The energy consumption of the indoor unit is significantly decreased by adaption of DC fan motor, with the efficiency enhanced significantly especially during low speed operation.



- Only 300mm in height, the thin unit can be installed in a ceiling space as narrow as 350mm.

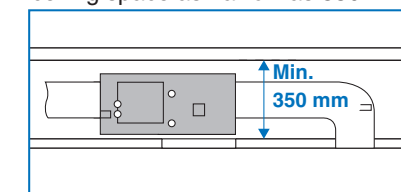

- Drain pump is equipped as standard accessory with 700 mm lift.

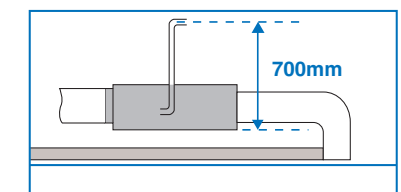

FXMQ200MA / FXMQ250MA



- Simplified Static Pressure Control
External static pressure can be easily adjusted using a change-over switch inside the electrical box to meet the resistance in the duct system.

- Built-in Drain Pump (Option)

Housing the drain pump inside the unit reduces the space required for installation.

- Without drain pump

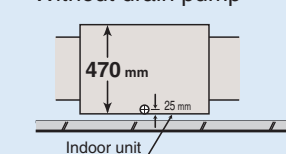

- With drain pump

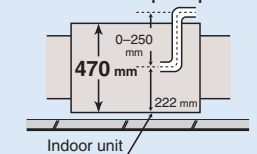

4-Way Flow Ceiling Suspended Type

FXUQ71A / FXUQ100A



This slim and stylish indoor unit achieves optimum air distribution, and can be installed without the need for ceiling cavity.

- Unit body and suction panel adopted round shapes and realised a slim appearance design. The unit can be used for various locations such as the ceilings with no cavity and bare ceilings.



- Flaps close automatically when the unit stops, which gives a simple appearance.

- Unified slim height of 198 mm for all models that gives the unified impression even when models with different capacities are installed in the same area.

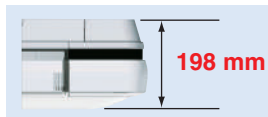

- With adoption of the individual flap control, airflow direction adjustment can be individually set for each air outlet. 5 directions of airflow and auto-swing can be selected with wired remote controller BRC1E62, which realises the optimum air distribution.

Individual airflow direction example case

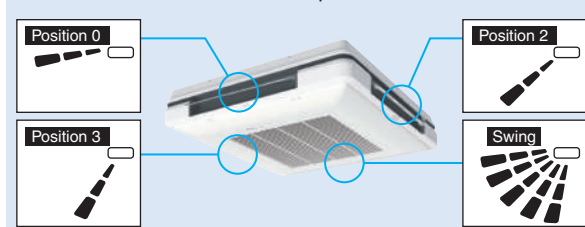

- The airflow rate can be controlled from 3-step control. Auto airflow rate control can be selected with wired remote controller BRC1E62.



- Energy efficiency has been improved thanks to the adoption of a new heat exchanger with smaller tubes, DC fan motor and DC drain pump motor.

- Drain pump is equipped as a standard accessory with 600 mm lift.

- Depending on installation site requirements or room conditions, 2-way, 3-way and 4-way discharge patterns are available.

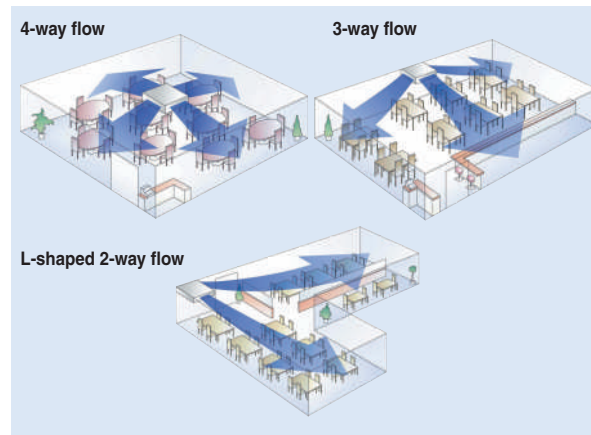

Ceiling Suspended Type

FXHQ32MA / FXHQ63MA
FXHQ100MA



Slim body with quiet and wide airflow

- Adoption of QUIET STREAM FAN

Uses the quiet stream fan and many more advanced technologies.

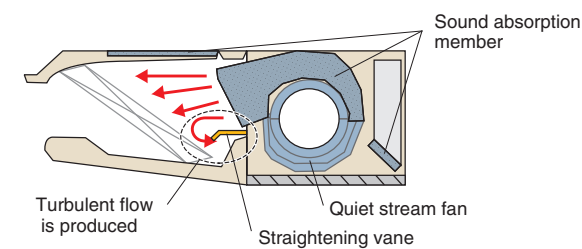

- Low operation sound level

	(dB(A))		
FXHQ-MA	32	63	100
Sound level (H/L)	36/31	39/34	45/37

- Installation is easy

- Drain pump kit (option) can be easily incorporated.

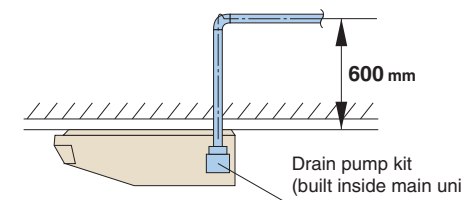

- Wide air discharge openings produce a spreading 100° airflow.

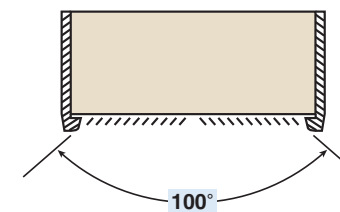

- Maintenance is easy

- Non-dew Flap with no implanted bristles

Bristle-free Flap minimises contamination and makes cleaning simpler.

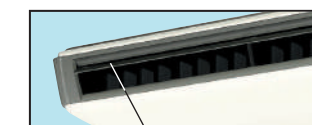

Non-dew Flap

- Easy-to-clean flat design

- Maintenance is easier because everything can be performed from below the unit.

- A long-life filter (maintenance free up to one year*) is equipped as standard accessory.

* 8 hr/day, 25 day/month. For dust concentration of 0.15 mg/m³

Wall Mounted Type

FXAQ20P / FXAQ25P
FXAQ32P / FXAQ40P
FXAQ50P / FXAQ63P



Stylish flat panel design harmonised with your interior décor

- Stylish flat panel design creates a graceful harmony that enhances any interior space.
- Flat panel can be cleaned with only the single pass of a cloth across their smooth surface. Flat panel can also be easily removed and washed for more thorough cleaning.

● Low operation sound level (dB(A))

FXAQ-P	20	25	32	40	50	63
Sound level (H/L)	35/31	36/31	38/31	39/34	42/37	47/41

- Drain pan and air filter can be kept clean by mould-proof polystyrene.
- Vertical auto-swing realises efficiency of air distribution. The louvre closes automatically when the unit stops.
- 5 steps of discharge angle can be set by remote controller.
- Discharge angle is automatically set at the same angle as the previous operation when restarting. (Initial setting: 10° for cooling and 70° for heating)
- Flexible installation
 - Drain pipe can be fitted to from either left or right sides.



- Drain pump kit is available as optional accessory, which lifts the drain 1,000 mm from the bottom of the unit.

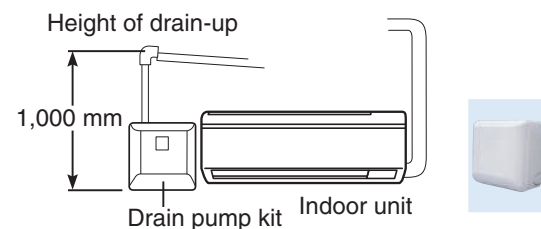

Floor Standing Type

FXLQ20MA / FXLQ25MA
FXLQ32MA / FXLQ40MA
FXLQ50MA / FXLQ63MA



Suitable for perimeter zone air conditioning

- Floor Standing types can be hung on the wall for easier cleaning. Running the piping from the back allows the unit to be hung on walls. Cleaning under the unit, where dust tends to accumulate, is considerably easier.
- The adoption of a fibre-less discharge grille featuring an original design to prevent condensation also helps prevent staining and makes cleaning easier.
- A long-life filter (maintenance free up to one year*) is equipped as standard accessory.

* 8 hr/day, 25 day/month. For dust concentration of 0.15 mg/m³

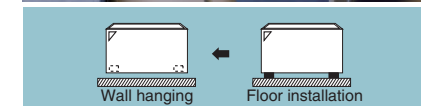

Concealed Floor Standing Type

FXNQ20MA / FXNQ25MA
FXNQ32MA / FXNQ40MA
FXNQ50MA / FXNQ63MA



Designed to be concealed in the perimeter skirting-wall

- The unit is concealed in skirting-wall of perimeter, that enables to create high class interior design.
- The connecting port faces downward, greatly facilitating on-site piping work.
- A long-life filter (maintenance free up to one year*) is equipped as standard accessory.

* 8 hr/day, 25 day/month. For dust concentration of 0.15 mg/m³

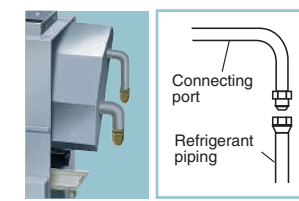

* Applies also to Floor Standing type (FXLQ-MA).



Indoor Units

Ceiling Mounted Cassette (Round Flow with Sensing) Type



MODEL		FXFSQ25AVE	FXFSQ32AVE	FXFSQ40AVE	FXFSQ50AVE	FXFSQ63AVE	FXFSQ71AVE
Power supply		1-phase, 60 Hz, 220 V					
Cooling capacity	kcal/h	2,400	3,100	3,900	4,800	6,100	6,900
	Btu/h	9,600	12,300	15,400	19,100	24,200	27,300
	kW	2.8	3.6	4.5	5.6	7.1	8.0
Heating capacity	kcal/h	2,800	3,400	4,300	5,400	6,900	7,700
	Btu/h	10,900	13,600	17,100	21,500	27,300	30,700
	kW	3.2	4.0	5.0	6.3	8.0	9.0
Power consumption	Cooling	0.049		0.059		0.214	
	Heating	0.045		0.055		0.210	
Casing		Galvanised steel plate					
Airflow rate (H/M/L)	m ³ /min	12.5/10.8/9.0		13.5/11.4/9.0		30/25/20	
	cfm	441/381/318		476/402/318		1,059/883/706	
Sound level (H/M/L)	dB(A)	30/28/25		32/29/25		44/39/34	
Dimensions (HxWxD)	mm	204x840x840			288x840x840		
Machine weight	kg	20			26		
Piping connections	Liquid (Flare)	φ6.4			φ9.5		
	Gas (Flare)	φ12.7			φ15.9		
	Drain	VP25 (External Dia, 32/Internal Dia, 25)					
Panel (Option)	Model	BYCSP125BW1					
	Colour	Fresh white					
	Dimensions(HxWxD)	50x950x950					
	Weight	5.5					

MODEL		FXFSQ80AVE	FXFSQ90AVE	FXFSQ100AVE	FXFSQ112AVE	FXFSQ125AVE
Power supply		1-phase, 60 Hz, 220 V				
Cooling capacity	kcal/h	7,700	8,600	9,600	10,800	12,000
	Btu/h	30,700	34,100	38,200	42,700	47,800
	kW	9.0	10.0	11.2	12.5	14.0
Heating capacity	kcal/h	9,000	9,600	10,800	12,000	13,800
	Btu/h	34,100	38,200	42,700	47,800	54,600
	kW	10.0	11.2	12.5	14.0	16.0
Power consumption	Cooling	0.214				
	Heating	0.210				
Casing		Galvanised steel plate				
Airflow rate (H/M/L)	m ³ /min	30/25/20				
	cfm	1,059/883/706				
Sound level (H/M/L)	dB(A)	44/39/34				
Dimensions (HxWxD)	mm	288x840x840				
Machine weight	kg	26				
Piping connections	Liquid (Flare)	φ9.5				
	Gas (Flare)	φ15.9				
	Drain	VP25 (External Dia, 32/Internal Dia, 25)				
Panel (Option)	Model	BYCSP125BW1				
	Colour	Fresh white				
	Dimensions(HxWxD)	50x950x950				
	Weight	5.5				

Note: Specifications are based on the following conditions:

- Cooling: Indoor temp.: 27°CDB, 19°CWB, Outdoor temp.: 35°CDB, Equivalent piping length: 7.5 m, Level difference: 0 m.
- Heating: Indoor temp.: 20°CDB, Outdoor temp.: 7°CDB, 6°CWB, Equivalent piping length: 7.5 m, Level difference: 0 m.
- Capacity of indoor unit is only for reference. Actual capacity of indoor unit is based on the total capacity index. (See Engineering Data Book for details.)
- Sound level: Anechoic chamber conversion value, measured at a point 1.5 m downward from the unit centre. During actual operation, these values are normally somewhat higher as a result of ambient conditions.

Ceiling Mounted Cassette (Round Flow) Type



MODEL		FXFQ25AVE	FXFQ32AVE	FXFQ40AVE	FXFQ50AVE	FXFQ63AVE	FXFQ71AVE
Power supply		1-phase, 60 Hz, 220 V					
Cooling capacity	kcal/h	2,400	3,100	3,900	4,800	6,100	6,900
	Btu/h	9,600	12,300	15,400	19,100	24,200	27,300
	kW	2.8	3.6	4.5	5.6	7.1	8.0
Heating capacity	kcal/h	2,800	3,400	4,300	5,400	6,900	7,700
	Btu/h	10,900	13,600	17,100	21,500	27,300	30,700
	kW	3.2	4.0	5.0	6.3	8.0	9.0
Power consumption	Cooling	0.053		0.063		0.074	
	Heating	0.045		0.055		0.069	
Casing		Galvanised steel plate					
Airflow rate (H/M/L)	m ³ /min	12.5/10.8/9.0		13.5/11.3/9.0		15.4/12.8/10.2	
	cfm	441/381/318		477/399/318		544/452/360	
Sound level (H/M/L)	dB(A)	30/28/25		32/29/25		33/30/27	
Dimensions (HxWxD)	mm	204x840x840					246x840x840
Machine weight	kg	20			21		24
Piping connections	Liquid (Flare)	φ6.4			φ9.5		
	Gas (Flare)	φ12.7			φ15.9		
	Drain	VP25 (External Dia, 32/Internal Dia, 25)					
Panel (Option)	Model	BYCP125K-W1					
	Colour	Fresh white					
	Dimensions(HxWxD)	50x950x950					
	Weight	5.5					

MODEL		FXFQ80AVE	FXFQ90AVE	FXFQ100AVE	FXFQ112AVE	FXFQ125AVE
Power supply		1-phase, 60 Hz, 220 V				
Cooling capacity	kcal/h	7,700	8,600	9,600	10,800	12,000
	Btu/h	30,700	34,100	38,200	42,700	47,800
	kW	9.0	10.0	11.2	12.5	14.0
Heating capacity	kcal/h	9,000	9,600	10,800	12,000	13,800
	Btu/h	34,100	38,200	42,700	47,800	54,600
	kW	10.0	11.2	12.5	14.0	16.0
Power consumption	Cooling	0.111		0.156		0.220
	Heating	0.100		0.142		0.210
Casing		Galvanised steel plate				
Airflow rate (H/M/L)	m ³ /min	23.1/18.8/14.5		25.4/21.1/16.8		30/25/20
	cfm	815/664/512		897/745/593		1,059/883/706
Sound level (H/M/L)	dB(A)	38/34/29		41/37/33		44/39/34
Dimensions (HxWxD)	mm	246x840x840				288x840x840
Machine weight	kg	24			26	
Piping connections	Liquid (Flare)	φ9.5				
	Gas (Flare)	φ15.9				
	Drain	VP25 (External Dia, 32/Internal Dia, 25)				
Panel (Option)	Model	BYCP125K-W1				
	Colour	Fresh white				
	Dimensions(HxWxD)	50x950x950				
	Weight	5.5				

Note: Specifications are based on the following conditions:

- Cooling: Indoor temp.: 27°CDB, 19°CWB, Outdoor temp.: 35°CDB, Equivalent piping length: 7.5 m, Level difference: 0 m.
- Heating: Indoor temp.: 20°CDB, Outdoor temp.: 7°CDB, 6°CWB, Equivalent piping length: 7.5 m, Level difference: 0 m.
- Capacity of indoor unit is only for reference. Actual capacity of indoor unit is based on the total capacity index. (See Engineering Data Book for details.)
- Sound level: Anechoic chamber conversion value, measured at a point 1.5 m downward from the unit centre. During actual operation, these values are normally somewhat higher as a result of ambient conditions.

Indoor Units

Ceiling Mounted Cassette (Compact Multi Flow) Type



MODEL		FXZQ20MVE	FXZQ25MVE	FXZQ32MVE	FXZQ40MVE	FXZQ50MVE
Power supply		1-phase, 220-240 V/220 V, 50 Hz/60 Hz				
Cooling capacity	kcal/h	1,900	2,400	3,100	3,900	4,800
	Btu/h	7,500	9,600	12,300	15,400	19,100
	kW	2.2	2.8	3.6	4.5	5.6
Heating capacity	kcal/h	2,200	2,800	3,400	4,300	5,400
	Btu/h	8,500	10,900	13,600	17,100	21,500
	kW	2.5	3.2	4.0	5.0	6.3
Power consumption	Cooling	0.075		0.080	0.095	0.128
	Heating	0.069		0.073	0.088	0.122
Casing		Galvanised steel plate				
Airflow rate (H/L)	m ³ /min	9/7		9.5/7.5	11/8	14/10
	cfm	318/247		335/265	388/282	493/353
Sound level (H/L)	dB(A)	32/29		33/29	36/30	41/34
Dimensions (HxWxD)	mm	286x575x575				
Machine weight	kg	18				
Piping connections	Liquid (Flare)	φ6.4				
	Gas (Flare)	φ12.7				
	Drain	VP20 (External Dia, 26/Internal Dia, 20)				
Panel (Option)	Model	BYFQ60B3W1				
	Colour	White (6.5Y9.5/0.5)				
	Dimensions(HxWxD)	55x700x700				
	Weight	2.7				

Ceiling Mounted Cassette (Double Flow) Type



MODEL		FXCQ20MVE	FXCQ25MVE	FXCQ32MVE	FXCQ40MVE	FXCQ50MVE	FXCQ63MVE	FXCQ80MVE	FXCQ125MVE
Power supply		1-phase, 220-240 V/220 V, 50/60 Hz							
Cooling capacity	kcal/h	1,900	2,400	3,100	3,900	4,800	6,100	7,700	12,000
	Btu/h	7,500	9,600	12,300	15,400	19,100	24,200	30,700	47,800
	kW	2.2	2.8	3.6	4.5	5.6	7.1	9.0	14.0
Heating capacity	kcal/h	2,200	2,800	3,400	4,300	5,400	6,900	9,000	13,800
	Btu/h	8,500	10,900	13,600	17,100	21,500	27,300	34,100	54,600
	kW	2.5	3.2	4.0	5.0	6.3	8.0	10.0	16.0
Power consumption	Cooling	0.081	0.095	0.132	0.157	0.216	0.278		
	Heating	0.048	0.062	0.099	0.124	0.183	0.245		
Casing		Galvanised steel plate							
Airflow rate (H/L)	m ³ /min	7/5	9/6.5	12/9	16.5/13	26/21	33/25		
	cfm	247/177	318/229	424/318	582/459	918/741	1,165/883		
Sound level (H/L)	dB(A)	32/27	34/28	34/29	37/32	39/34	44/38		
Dimensions (HxWxD)	mm	305x775x600		305x990x600	305x1,175x600	305x1,665x600			
Machine weight	kg	26		31	32	35	47	48	
Piping connections	Liquid (Flare)	φ6.4				φ9.5			
	Gas (Flare)	φ12.7				φ15.9			
	Drain	VP25 (External Dia, 32/Internal Dia, 25)							
Panel (Option)	Model	BYBC32G-W1		BYBC50G-W1	BYBC63G-W1	BYBC125G-W1			
	Colour	White (10Y9/0.5)							
	Dimensions(HxWxD)	53x1,030x680		53x1,245x680	53x1,430x680	53x1,920x680			
	Weight	8.0		8.5	9.5	12.0			

Note: Specifications are based on the following conditions;
 • Cooling: Indoor temp.: 27°CDB, 19°CWB, Outdoor temp.: 35°CDB, Equivalent piping length: 7.5 m, Level difference: 0 m.
 • Heating: Indoor temp.: 20°CDB, Outdoor temp.: 7°CDB, 6°CWB, Equivalent piping length: 7.5 m, Level difference: 0 m.
 • Capacity of indoor unit is only for reference. Actual capacity of indoor unit is based on the total capacity index. (See Engineering Data Book for details.)
 • Sound level: Anechoic chamber conversion value, measured at a point 1.5 m downward from the unit centre.
 During actual operation, these values are normally somewhat higher as a result of ambient conditions.

Ceiling Mounted Cassette (Single Flow) Type



MODEL		FXEQ20AVE	FXEQ25AVE	FXEQ32AVE	FXEQ40AVE	FXEQ50AVE	FXEQ63AVE	
Power supply		1-phase, 60 Hz, 220 V						
Cooling capacity	kcal/h	1,900	2,400	3,100	3,900	4,800	6,100	
	Btu/h	7,500	9,600	12,300	15,400	19,100	24,200	
	kW	2.2	2.8	3.6	4.5	5.6	7.1	
Heating capacity	kcal/h	2,200	2,800	3,400	4,300	5,400	6,900	
	Btu/h	8,500	10,900	13,600	17,100	21,500	27,300	
	kW	2.5	3.2	4.0	5.0	6.3	8.0	
Power consumption	Cooling	0.026	0.027	0.034	0.046	0.048	0.067	
	Heating	0.022	0.023	0.030	0.042	0.044	0.063	
Casing		Galvanised steel plate						
Airflow rate (H/HM/M/ML/L)	Cooling	m ³ /min	6.0/5.4/4.9/4.4/4.0	6.9/6.4/5.8/5.3/4.8	8.0/7.5/7.0/6.3/5.5	9.8/8.8/7.8/7.0/6.2	12.5/11.4/10.4/9.5/8.7	15.0/13.6/12.2/11.0/9.8
		cfm	212/191/173/155/141	244/228/205/187/169	282/265/247/222/194	346/311/275/247/219	441/402/367/335/307	530/480/431/388/346
	Heating	m ³ /min	6.0/5.6/5.1/4.7/4.2	7.2/6.7/6.1/5.6/5.0	8.6/8.0/7.4/6.7/6.0	10.2/9.3/8.4/7.6/6.8	14.0/12.8/11.6/10.7/9.8	16.9/15.3/13.6/12.3/11.0
		cfm	212/198/180/166/148	254/237/215/198/177	304/282/261/237/212	360/328/297/268/240	494/452/409/378/346	597/540/480/434/388
Sound level (H/HM/M/ML/L)	Cooling	dB(A)	30/29/28/27/26	32/31/30/29/28	35/34/33/32/30	38/37/35/33/31	43/41/39/37/35	
	Heating	dB(A)	33/31/29/28/26	35/33/31/30/26	38/36/34/33/31	41/39/37/35/33	41/39/37/36/34	45/44/42/40/38
Dimensions (HxWxD)	mm	200x840x470				200x1,240x470		
Machine weight	kg	17		18	23			
Piping connections	Liquid (Flare)	φ6.4					φ9.5	
	Gas (Flare)	φ12.7					φ15.9	
	Drain	PVC26 (External Dia, 26/Internal Dia, 20)						
Panel (Option)	Model	BYEP40AW1			BYEP63AW1			
	Colour	Fresh white						
	Dimensions(HxWxD)	80x950x550			80x1,350x550			
	Weight	8.0			10.0			

Slim Ceiling Mounted Duct Type (700 mm width type)

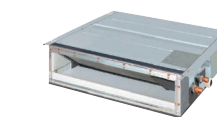

MODEL	with drain pump	FXDQ20PBVE	FXDQ25PBVE	FXDQ32PBVE	
	without drain pump	FXDQ20PBVET	FXDQ25PBVET	FXDQ32PBVET	
Power supply		1-phase, 220-240 V/220 V, 50/60 Hz			
Cooling capacity	kcal/h	1,900	2,400	3,100	
	Btu/h	7,500	9,600	12,300	
	kW	2.2	2.8	3.6	
Heating capacity	kcal/h	2,200	2,800	3,400	
	Btu/h	8,500	10,900	13,600	
	kW	2.5	3.2	4.0	
Power consumption (FXDQ-PBVE)*1	Cooling	0.092		0.095	
	Heating	0.073		0.076	
Power consumption (FXDQ-PBVET)*1	Cooling	0.073		0.076	
	Heating	0.073		0.076	
Casing		Galvanised steel plate			
Airflow rate (HH/H/L)	m ³ /min	8.0/7.2/6.4			
	cfm	282/254/226			
External static pressure	Pa	30-10*2			
Sound level (HH/H/L)*1*3	dB(A)	28/26/23		28/26/24	
Dimensions (HxWxD)	mm	200x700x620			
Machine weight	kg	23			
Piping connections	Liquid (Flare)	φ6.4			
	Gas (Flare)	φ12.7			
	Drain	VP20 (External Dia, 26/Internal Dia, 20)			

Note: Specifications are based on the following conditions;
 • Cooling: Indoor temp.: 27°CDB, 19°CWB, Outdoor temp.: 35°CDB, Equivalent piping length: 7.5 m, Level difference: 0 m.
 • Heating: Indoor temp.: 20°CDB, Outdoor temp.: 7°CDB, 6°CWB, Equivalent piping length: 7.5 m, Level difference: 0 m.
 • Capacity of indoor unit is only for reference. Actual capacity of indoor unit is based on the total capacity index. (See Engineering Data Book for details.)
 • Sound level: (FXEQ-A) Anechoic chamber conversion value, measured at a point 1 m in front of the unit and 1 m downward.
 (FXDQ-PB) Anechoic chamber conversion value, measured at a point 1.5 m downward from the unit centre.
 During actual operation, these values are normally somewhat higher as a result of ambient conditions.
 *1: Values are based on the following conditions: FXDQ-PB: external static pressure of 10 Pa; FXDQ-NB: external static pressure of 15 Pa.
 *2: External static pressure is changeable to set by the remote controller. This pressure means "High static pressure - Standard". (Factory setting is 10 Pa for FXDQ-PB models and 15 Pa for FXDQ-NB models.)
 *3: The values of operation sound level represent those for rear-suction operation. Sound level values for bottom-suction operation can be obtained by adding 5 dB(A).

Indoor Units

Slim Ceiling Mounted Duct Type (900/1,100 mm width type)

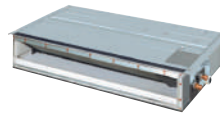

MODEL	with drain pump	FXDQ40NBVE	FXDQ50NBVE	FXDQ63NBVE	
	without drain pump	FXDQ40NBVET	FXDQ50NBVET	FXDQ63NBVET	
Power supply		1-phase, 220-240 V/220 V, 50/60 Hz			
Cooling capacity	kcal/h	3,900	4,800	6,100	
	Btu/h	15,400	19,100	24,200	
	kW	4.5	5.6	7.1	
Heating capacity	kcal/h	4,300	5,400	6,900	
	Btu/h	17,100	21,500	27,300	
	kW	5.0	6.3	8.0	
Power consumption (FXDQ-NBVE)*1	Cooling	0.182	0.185	0.192	
	Heating				0.168
Power consumption (FXDQ-NBVET)*1	Cooling	0.168	0.170	0.179	
	Heating				0.168
Casing		Galvanised steel plate			
Airflow rate (HH/H/L)	m ³ /min	10.5/9.5/8.5	12.5/11/10	16.5/14.5/13	
	cfm	371/335/300	441/388/353	582/512/459	
External static pressure	Pa	44-15*2			
Sound level (HH/H/L)*1*3	dB(A)	30/28/26	33/30/27	33/31/29	
Dimensions (HxWxD)	mm	200x900x620		200x1,100x620	
Machine weight	kg	27	28	31	
Piping connections	Liquid (Flare)	φ6.4			
	Gas (Flare)	φ12.7			
	Drain	VP20 (External Dia, 26/Internal Dia, 20)			

Ceiling Mounted Duct Type



MODEL	FXMQ20AVE	FXMQ25AVE	FXMQ32AVE	FXMQ36AVE	FXMQ40AVE	FXMQ50AVE	
Power supply		1-phase, 60 Hz, 220 V					
Cooling capacity	kcal/h	1,900	2,400	3,100	3,400	3,900	4,800
	Btu/h	7,500	9,600	12,300	13,600	15,400	19,100
	kW	2.2	2.8	3.6	4.0	4.5	5.6
Heating capacity	kcal/h	2,200	2,800	3,400	3,900	4,300	5,400
	Btu/h	8,500	10,900	13,600	15,400	17,100	21,500
	kW	2.5	3.2	4.0	4.5	5.0	6.3
Power consumption	Cooling	0.081		0.085		0.194	
	Heating	0.069		0.073		0.203	
Casing		Galvanised steel plate					
Airflow rate (HH/H/L)	m ³ /min	9/7.5/6.5		9.5/8/7		16/13/11	
	cfm	318/265/229		335/282/247		565/459/388	
External static pressure	Pa	30-100*4		30-160*4		50-200*4	
Sound level (HH/H/L)	dB(A)	33/31/29		34/32/30		39/37/35	
Dimensions (HxWxD)	mm	300x550x700			300x700x700		300x1,000x700
Machine weight	kg	24			27		35
Piping connections	Liquid (Flare)	φ6.4					
	Gas (Flare)	φ12.7					
	Drain	VP25 (External Dia, 32/Internal Dia, 25)					

Note: Specifications are based on the following conditions;

- Cooling: Indoor temp.: 27°CDB, 19°CWB, Outdoor temp.: 35°CDB, Equivalent piping length: 7.5 m, Level difference: 0 m.
 - Heating: Indoor temp.: 20°CDB, Outdoor temp.: 7°CDB, 6°CWB, Equivalent piping length: 7.5 m, Level difference: 0 m.
 - Capacity of indoor unit is only for reference. Actual capacity of indoor unit is based on the total capacity index. (See Engineering Data Book for details.)
 - Sound level: Anechoic chamber conversion value, measured at a point 1.5 m downward from the unit centre.
- During actual operation, these values are normally somewhat higher as a result of ambient conditions.
- *1: Values are based on the following conditions: FXDQ-PB: external static pressure of 10 Pa; FXDQ-NB: external static pressure of 15 Pa.
 - *2: External static pressure is changeable to set by the remote controller. This pressure means "High static pressure - Standard". (Factory setting is 10 Pa for FXDQ-PB models and 15 Pa for FXDQ-NB models.)
 - *3: The values of operation sound level represent those for rear-suction operation. Sound level values for bottom-suction operation can be obtained by adding 5 dB(A).
 - *4: External static pressure can be modified using a remote controller that offers seven (FXMQ20-32A), thirteen (FXMQ40A), fourteen (FXMQ50-125A) levels of control. These values indicate the lowest and highest possible static pressures. The standard static pressure is 50 Pa for FXMQ20-32A and 100 Pa for FXMQ36-125A.

Ceiling Mounted Duct Type



MODEL	FXMQ56AVE	FXMQ63AVE	FXMQ80AVE	FXMQ100AVE	FXMQ125AVE	FXMQ140PVE	
Power supply		1-phase, 60 Hz, 220 V					
Cooling capacity	kcal/h	5,400	6,100	7,700	9,600	12,000	13,800
	Btu/h	21,500	24,200	30,700	38,200	47,800	54,600
	kW	6.3	7.1	9.0	11.2	14.0	16.0
Heating capacity	kcal/h	6,100	6,900	9,000	10,800	13,800	15,500
	Btu/h	24,200	27,300	34,100	42,700	54,600	61,400
	kW	7.1	8.0	10.0	12.5	16.0	18.0
Power consumption	Cooling	0.230		0.298		0.404	
	Heating	0.218		0.286		0.380	
Casing		Galvanised steel plate					
Airflow rate (HH/H/L)	m ³ /min	19.5/17.5/16		25/22.5/20		32/27/23	
	cfm	688/618/565		883/794/706		1,130/953/812	
External static pressure	Pa	50-200*1					50-140*1
Sound level (HH/H/L)	dB(A)	42/40/38		43/41/39		44/42/40	
Dimensions (HxWxD)	mm	300x1,000x700			300x1,400x700		
Machine weight	kg	35			45		47
Piping connections	Liquid (Flare)	φ9.5					
	Gas (Flare)	φ15.9					
	Drain	VP25 (External Dia, 32/Internal Dia, 25)					

Ceiling Mounted Duct Type



MODEL	FXMQ200MAVE	FXMQ250MAVE	
Power supply		1-phase, 220-240 V/220 V, 50/60 Hz	
Cooling capacity	kcal/h	19,300	24,100
	Btu/h	76,400	95,500
	kW	22.4	28.0
Heating capacity	kcal/h	21,500	27,100
	Btu/h	85,300	107,500
	kW	25.0	31.5
Power consumption	Cooling	1,490	
	Heating	1,684	
Casing		Galvanised steel plate	
Airflow rate (H/L)	m ³ /min	58/50	
	cfm	2,047/1,765	
External static pressure	Pa	132-270*2	
Sound level (H/L)	dB(A)	48/45	
Dimensions (HxWxD)	mm	470x1,380x1,100	
Machine weight	kg	137	
Piping connections	Liquid (Flare)	φ9.5	
	Gas (Flare)	φ19.1	
	Drain	PS1B	

Note: Specifications are based on the following conditions;

- Cooling: Indoor temp.: 27°CDB, 19°CWB, Outdoor temp.: 35°CDB, Equivalent piping length: 7.5 m, Level difference: 0 m.
 - Heating: Indoor temp.: 20°CDB, Outdoor temp.: 7°CDB, 6°CWB, Equivalent piping length: 7.5 m, Level difference: 0 m.
 - Capacity of indoor unit is only for reference. Actual capacity of indoor unit is based on the total capacity index. (See Engineering Data Book for details.)
 - Sound level: Anechoic chamber conversion value, measured at a point 1.5 m downward from the unit centre.
- During actual operation, these values are normally somewhat higher as a result of ambient conditions.
- *1: External static pressure can be modified using a remote controller that offers seven (FXMQ20-32A), thirteen (FXMQ40A), fourteen (FXMQ50-125A) or ten (FXMQ140P) levels of control. These values indicate the lowest and highest possible static pressures. The standard static pressure is 50 Pa for FXMQ20-32A and 100 Pa for FXMQ36-125A and FXMQ140P.
 - *2: External static pressure is changeable to change over the connectors inside electrical box, this pressure means "Standard-High static pressure".

Indoor Units

4-Way Flow Ceiling Suspended Type



MODEL		FXUQ71AVEB	FXUQ100AVEB
Power supply		1-phase, 220-240/220-230 V, 50/60 Hz	
Cooling capacity	kcal/h	6,900	9,600
	Btu/h	27,300	38,200
	kW	8.0	11.2
Heating capacity	kcal/h	7,700	10,800
	Btu/h	30,700	42,700
	kW	9.0	12.5
Power consumption	Cooling	0.090	0.200
	Heating	0.073	0.179
Casing colour		Fresh white	
Airflow rate (H/M/L)	m ³ /min	22.5/19.5/16	31/26/21
	cfm	794/688/565	1,094/918/741
Sound level (H/M/L)	dB(A)	40/38/36	47/44/40
Dimensions (HxWxD)	mm	198x950x950	
Machine weight	kg	26	27
Piping connections	Liquid (Flare)	φ9.5	
	Gas (Flare)	φ15.9	
	Drain	VP20 (External Dia, 26/Internal Dia, 20)	

Ceiling Suspended Type



MODEL		FXHQ32MAVE	FXHQ63MAVE	FXHQ100MAVE
Power supply		1-phase, 220-240 V/220 V, 50/60 Hz		
Cooling capacity	kcal/h	3,100	6,100	9,600
	Btu/h	12,300	24,200	38,200
	kW	3.6	7.1	11.2
Heating capacity	kcal/h	3,400	6,900	10,800
	Btu/h	13,600	27,300	42,700
	kW	4.0	8.0	12.5
Power consumption	Cooling	0.142	0.145	0.199
	Heating	0.142	0.145	0.199
Casing		White (10Y9/0.5)		
Airflow rate (H/L)	m ³ /min	12/10	17.5/14	25/19.5
	cfm	424/353	618/494	883/688
Sound level (H/L)	dB(A)	36/31	39/34	45/37
Dimensions (HxWxD)	mm	195x960x680	195x1,160x680	195x1,400x680
Machine weight	kg	24	28	33
Piping connections	Liquid (Flare)	φ6.4	φ9.5	
	Gas (Flare)	φ12.7	φ15.9	
	Drain	VP20 (External Dia, 26/Internal Dia, 20)		

Note: Specifications are based on the following conditions:

- Cooling: Indoor temp.: 27°CDB, 19°CWB, Outdoor temp.: 35°CDB, Equivalent piping length: 7.5 m, Level difference: 0 m.
- Heating: Indoor temp.: 20°CDB, Outdoor temp.: 7°CDB, 6°CWB, Equivalent piping length: 7.5 m, Level difference: 0 m.
- Capacity of indoor unit is only for reference. Actual capacity of indoor unit is based on the total capacity index. (See Engineering Data Book for details.)
- Sound level: Anechoic chamber conversion value, measured at a point 1 m in front of the unit and 1 m downward. During actual operation, these values are normally somewhat higher as a result of ambient conditions.

Wall Mounted Type



MODEL		FXAQ20PVE	FXAQ25PVE	FXAQ32PVE	FXAQ40PVE	FXAQ50PVE	FXAQ63PVE
Power supply		1-phase, 220-240 V/220 V, 50/60 Hz					
Cooling capacity	kcal/h	1,900	2,400	3,100	3,900	4,800	6,100
	Btu/h	7,500	9,600	12,300	15,400	19,100	24,200
	kW	2.2	2.8	3.6	4.5	5.6	7.1
Heating capacity	kcal/h	2,200	2,800	3,400	4,300	5,400	6,900
	Btu/h	8,500	10,900	13,600	17,100	21,500	27,300
	kW	2.5	3.2	4.0	5.0	6.3	8.0
Power consumption	Cooling	0.019	0.028	0.030	0.020	0.033	0.050
	Heating	0.029	0.034	0.035	0.020	0.039	0.060
Casing		White (3.0Y8.5/0.5)					
Airflow rate (H/L)	m ³ /min	7.5/4.5	8/5	8.5/5.5	12/9	15/12	19/14
	cfm	265/159	282/177	300/194	424/318	530/424	671/494
Sound level (H/L)	dB(A)	35/31	36/31	38/31	39/34	42/37	47/41
Dimensions (HxWxD)	mm	290x795x238			290x1,050x238		
Machine weight	kg	11			14		
Piping connections	Liquid (Flare)	φ6.4					φ9.5
	Gas (Flare)	φ12.7					φ15.9
	Drain	VP13 (External Dia, 18/Internal Dia, 13)					

Floor Standing Type/Concealed Floor Standing Type



FXLQ



FXNQ

MODEL		FXLQ20MAVE	FXLQ25MAVE	FXLQ32MAVE	FXLQ40MAVE	FXLQ50MAVE	FXLQ63MAVE
		FXNQ20MAVE	FXNQ25MAVE	FXNQ32MAVE	FXNQ40MAVE	FXNQ50MAVE	FXNQ63MAVE
Power supply		1-phase, 220-240 V/220 V, 50/60 Hz					
Cooling capacity	kcal/h	1,900	2,400	3,100	3,900	4,800	6,100
	Btu/h	7,500	9,600	12,300	15,400	19,100	24,200
	kW	2.2	2.8	3.6	4.5	5.6	7.1
Heating capacity	kcal/h	2,200	2,800	3,400	4,300	5,400	6,900
	Btu/h	8,500	10,900	13,600	17,100	21,500	27,300
	kW	2.5	3.2	4.0	5.0	6.3	8.0
Power consumption	Cooling	0.047		0.079	0.084	0.105	0.108
	Heating	0.047		0.079	0.084	0.105	0.108
Casing		FXLQ: Ivory white (5Y7.5/1)/FXNQ: Galvanised steel plate					
Airflow rate (H/L)	m ³ /min	7/6		8/6	11/8.5	14/11	16/12
	cfm	247/212		282/212	388/300	494/388	565/424
Sound level (H/L)	dB(A)	35/32			38/33	39/34	40/35
Dimensions (HxWxD)	FXLQ	600x1,000x222		600x1,140x222		600x1,420x222	
	FXNQ	610x930x220		610x1,070x220		610x1,350x220	
Machine weight	FXLQ	25		30		36	
	FXNQ	19		23		27	
Piping connections	Liquid (Flare)	φ6.4					φ9.5
	Gas (Flare)	φ12.7					φ15.9
	Drain	φ21 O.D (Vinyl chloride)					

Note: Specifications are based on the following conditions:

- Cooling: Indoor temp.: 27°CDB, 19°CWB, Outdoor temp.: 35°CDB, Equivalent piping length: 7.5 m, Level difference: 0 m.
- Heating: Indoor temp.: 20°CDB, Outdoor temp.: 7°CDB, 6°CWB, Equivalent piping length: 7.5 m, Level difference: 0 m.
- Capacity of indoor unit is only for reference. Actual capacity of indoor unit is based on the total capacity index. (See Engineering Data Book for details.)
- Sound level: (FXAQ-P) Anechoic chamber conversion value, measured at a point 1 m in front of the unit and 1 m downward. (FXLQ-MA, FXNQ-MA) Anechoic chamber conversion value, measured at a point 1.5 m in front of the unit at a height of 1.5 m. During actual operation, these values are normally somewhat higher as a result of ambient conditions.

Outdoor Unit Combinations

RHXYQ-A

HP	Capacity index	Model name	Combination	Outdoor unit multi connection piping kit *1	Total capacity index of connectable indoor units *2	Maximum number of connectable indoor units
8	200	RHXYQ8AYL/TL	RHXYQ8AYL/TL	—	100 to 260	13
10	250	RHXYQ10AYL/TL	RHXYQ10AYL/TL	—	125 to 325	16
12	300	RHXYQ12AYL/TL	RHXYQ12AYL/TL	—	150 to 390	19
14	350	RHXYQ14AYL/TL	RHXYQ14AYL/TL	—	175 to 455	22
16	400	RHXYQ16AYL/TL	RHXYQ16AYL/TL	—	200 to 520	26
18	450	RHXYQ18AYL/TL	RHXYQ18AYL/TL	—	225 to 585	29
20	500	RHXYQ20AYL/TL	RHXYQ20AYL/TL	—	250 to 650	32
22	550	RHXYQ22AYL/TL	RHXYQ22AYL/TL	—	275 to 715	35
24	600	RHXYQ24AYL/TL	RHXYQ12AYL/TL × 2	BHFP22P100	300 to 780	39
26	650	RHXYQ26AYL/TL	RHXYQ10AYL/TL + RHXYQ16AYL/TL		325 to 845	42
28	700	RHXYQ28AYL/TL	RHXYQ12AYL/TL + RHXYQ16AYL/TL		350 to 910	45
30	750	RHXYQ30AYL/TL	RHXYQ8AYL/TL + RHXYQ22AYL/TL		375 to 975	48
32	800	RHXYQ32AYL/TL	RHXYQ10AYL/TL + RHXYQ22AYL/TL		400 to 1,040	52
34	850	RHXYQ34AYL/TL	RHXYQ12AYL/TL + RHXYQ22AYL/TL		425 to 1,105	55
36	900	RHXYQ36AYL/TL	RHXYQ14AYL/TL + RHXYQ22AYL/TL		450 to 1,170	58
38	950	RHXYQ38AYL/TL	RHXYQ16AYL/TL + RHXYQ22AYL/TL		475 to 1,235	61
40	1,000	RHXYQ40AYL/TL	RHXYQ18AYL/TL + RHXYQ22AYL/TL		500 to 1,300	64
42	1,050	RHXYQ42AYL/TL	RHXYQ20AYL/TL + RHXYQ22AYL/TL		525 to 1,365	
44	1,100	RHXYQ44AYL/TL	RHXYQ22AYL/TL × 2		550 to 1,430	
46	1,150	RHXYQ46AYL/TL	RHXYQ8AYL/TL + RHXYQ16AYL/TL + RHXYQ22AYL/TL		575 to 1,495	
48	1,200	RHXYQ48AYL/TL	RHXYQ10AYL/TL + RHXYQ16AYL/TL + RHXYQ22AYL/TL		600 to 1,560	
50	1,250	RHXYQ50AYL/TL	RHXYQ12AYL/TL + RHXYQ16AYL/TL + RHXYQ22AYL/TL		625 to 1,625	
52	1,300	RHXYQ52AYL/TL	RHXYQ10AYL/TL + RHXYQ20AYL/TL + RHXYQ22AYL/TL	650 to 1,690		
54	1,350	RHXYQ54AYL/TL	RHXYQ10AYL/TL + RHXYQ22AYL/TL × 2	675 to 1,755		
56	1,400	RHXYQ56AYL/TL	RHXYQ12AYL/TL + RHXYQ22AYL/TL × 2	700 to 1,820		
58	1,450	RHXYQ58AYL/TL	RHXYQ14AYL/TL + RHXYQ22AYL/TL × 2	725 to 1,885		
60	1,500	RHXYQ60AYL/TL	RHXYQ16AYL/TL + RHXYQ22AYL/TL × 2	750 to 1,950		
62	1,550	RHXYQ62AYL/TL	RHXYQ18AYL/TL + RHXYQ22AYL/TL × 2	775 to 2,015		
64	1,600	RHXYQ64AYL/TL	RHXYQ20AYL/TL + RHXYQ22AYL/TL × 2	800 to 2,080		
66	1,650	RHXYQ66AYL/TL	RHXYQ22AYL/TL × 3	825 to 2,145		

Note: *1 For multiple connection of 24 HP systems and above, the outdoor unit multi connection piping kit (separately sold) is required.
 *2 Total capacity index of connectable indoor units must be 50%–130% of the capacity index of the outdoor unit.

$$\text{Combination ratio} = \frac{\text{Total capacity index of the indoor units}}{\text{Capacity index of the outdoor unit}}$$

RXYQ-T

HP	Capacity index	Model name	Combination	Outdoor unit multi connection piping kit *1	Total capacity index of connectable indoor units *2	Maximum number of connectable indoor units *2	
7.5	188	RXYQ72T	RXYQ72T	—	94 to 244 (376)	12 (18)	
10	251	RXYQ96T	RXYQ96T	—	126 to 326 (502)	16 (25)	
12.5	314	RXYQ120T	RXYQ120T	—	157 to 408 (628)	20 (31)	
15	377	RXYQ144T	RXYQ144T	—	189 to 490 (754)	24 (37)	
17.5	439	RXYQ168T	RXYQ168T	—	220 to 570 (878)	28 (43)	
20	503	RXYQ192T	RXYQ72T + RXYQ120T	BHFP22P100U	252 to 653 (804)	32 (40)	
22.5	565	RXYQ216T	RXYQ96T + RXYQ120T		283 to 734 (904)	36 (45)	
25	629	RXYQ240T	RXYQ120T × 2		315 to 817 (1,006)	40 (50)	
27.5	691	RXYQ264T	RXYQ120T + RXYQ144T		346 to 898 (1,105)	44 (55)	
30	754	RXYQ288T	RXYQ144T × 2		377 to 980 (1,206)	49 (60)	
32.5	816	RXYQ312T	RXYQ144T + RXYQ168T		408 to 1,060 (1,305)	53 (64)	
35	879	RXYQ336T	RXYQ168T × 2		440 to 1,142 (1,406)	57 (64)	
37.5	938	RXYQ360T	RXYQ120T × 3		469 to 1,219 (1,219)	60 (60)	
40	1,000	RXYQ384T	RXYQ96T + RXYQ120T + RXYQ168T		BHFP22P151U	500 to 1,300 (1,300)	64 (64)
42.5	1,063	RXYQ408T	RXYQ96T + RXYQ144T + RXYQ168T			532 to 1,381 (1,381)	
45	1,125	RXYQ432T	RXYQ144T × 3			563 to 1,462 (1,462)	
47.5	1,188	RXYQ456T	RXYQ144T × 2 + RXYQ168T			594 to 1,544 (1,544)	
50	1,250	RXYQ480T	RXYQ144T + RXYQ168T × 2			625 to 1,625 (1,625)	
52.5	1,313	RXYQ504T	RXYQ168T × 3			657 to 1,706 (1,706)	

Note: *1 For multiple connection of 20 HP systems and above, the outdoor unit multi connection piping kit (separately sold) is required.
 *2 Values inside brackets are based on connection of indoor units rated at maximum capacity, 200% for single outdoor units, 160% for double outdoor units, and 130% for triple outdoor units.

$$\text{Combination ratio} = \frac{\text{Total capacity index of the indoor units}}{\text{Capacity index of the outdoor unit}}$$

Outdoor Units

RHXYQ-AYL

Heat Pump

MODEL			RHXYQ8AYL	RHXYQ10AYL	RHXYQ12AYL	RHXYQ14AYL	RHXYQ16AYL	RHXYQ18AYL	RHXYQ20AYL		RHXYQ22AYL	RHXYQ24AYL	RHXYQ26AYL	RHXYQ28AYL	RHXYQ30AYL	RHXYQ32AYL	RHXYQ34AYL	RHXYQ36AYL		
Combination units			-	-	-	-	-	-	-		-	RHXYQ12AYL	RHXYQ10AYL	RHXYQ12AYL	RHXYQ8AYL	RHXYQ10AYL	RHXYQ12AYL	RHXYQ14AYL		
Power supply			3-phase 4-wire system, 380 V, 60 Hz									3-phase 4-wire system, 380 V, 60 Hz								
Cooling capacity			kcal/h	19,300	24,100	28,800	34,400	38,700	43,000	48,200		52,900	57,600	62,800	67,500	72,200	77,000	81,700	86,900	
			Btu/h	76,400	95,500	114,000	136,000	154,000	171,000	191,000		210,000	229,000	249,000	268,000	286,000	305,000	324,000	345,000	
			kW	22.4	28.0	33.5	40.0	45.0	50.0	56.0		61.5	67.0	73.0	78.5	83.9	89.5	95.0	101	
Heating capacity			kcal/h	21,500	27,100	32,300	38,700	43,000	48,200	54,200		59,300	64,500	70,100	75,300	80,800	86,900	92,000	98,000	
			Btu/h	85,300	107,000	128,000	154,000	171,000	191,000	215,000		235,000	256,000	278,000	299,000	321,000	345,000	365,000	389,000	
			kW	25.0	31.5	37.5	45.0	50.0	56.0	63.0		69.0	75.0	81.5	87.5	94.0	101	107	114	
Power consumption			Cooling	kW	4.28	5.94	7.38	9.08	10.77	12.13	13.99		15.78	14.8	16.7	18.1	20.1	21.7	23.1	24.9
			Heating	kW	4.85	6.50	8.01	9.91	11.27	12.73	15.00		17.00	16.0	17.8	19.3	21.8	23.5	25.0	26.9
Capacity control			%	20-100	16-100	15-100	10-100	8-100			8-100	8-100	5-100	5-100	5-100	5-100	5-100	4-100		
Casing colour			Ivory White (5Y7.5/1)									Ivory White (5Y7.5/1)								
Compressor			Hermetically Sealed Scroll Type									Hermetically Sealed Scroll Type								
Motor output			kW	4.5x1	5.7x1	6.9x1	(4.1+4.4)x1	(4.6+5.0)x1	(4.9+5.8)x1	(5.0+7.4)x1		(5.0+7.4)x1	(6.9x1)+(6.9x1)	(5.7x1)+((4.6+5.0)x1)	(6.9x1)+((4.6+5.0)x1)	(4.5x1)+((5.0+7.4)x1)	(5.7x1)+((5.0+7.4)x1)	(6.9x1)+((5.0+7.4)x1)	((4.1+4.4)x1)+((5.0+7.4)x1)	
Airflow rate			m ³ /min	162	175	185	223	260	251	261		271	185+185	175+260	185+260	162+271	175+271	185+271	223+271	
Dimensions: (HxWxD)			mm	1,657x930x765				1,657x1,240x765				1,657x1,240x765	(1,657x930x765)+(1,657x930x765)	(1,657x930x765)+(1,657x1,240x765)						(1,657x1,240x765)+(1,657x1,240x765)
Machine weight			kg	184	191	213	285	285	317	317		317	213+213	191+285	213+285	184+317	191+317	213+317	285+317	
Sound level			dB(A)	57	58	60	60	60	61	62		63	63	62	63	64	64	65	65	
Operation range			Cooling	°CDB -5 to 43									°CDB -5 to 43							
			Heating	°CWB -20 to 15.5									°CWB -20 to 15.5							
Refrigerant			R-410A									R-410A								
Charge			kg	5.0	6.0	6.9			8.6			8.6	6.9+6.9	6.0+6.9	6.9+6.9	5.0+8.6	6.0+8.6	6.9+8.6		
Piping connections			Liquid	φ9.5 (Brazeing Connection)		φ12.7 (Brazeing Connection)			φ15.9 (Brazeing Connection)			φ15.9 (Brazeing Connection)	φ15.9 (Brazeing Connection)	φ19.1 (Brazeing Connection)	φ19.1 (Brazeing Connection)	φ19.1 (Brazeing Connection)	φ19.1 (Brazeing Connection)	φ19.1 (Brazeing Connection)	φ19.1 (Brazeing Connection)	
			Gas	φ19.1 (Brazeing Connection)		φ22.2 (Brazeing Connection)	φ25.4 (Brazeing Connection)		φ28.6 (Brazeing Connection)				φ28.6 (Brazeing Connection)	φ28.6 (Brazeing Connection)	φ31.8 (Brazeing Connection)	φ31.8 (Brazeing Connection)	φ31.8 (Brazeing Connection)	φ31.8 (Brazeing Connection)	φ31.8 (Brazeing Connection)	φ31.8 (Brazeing Connection)

Note: Specifications are based on the following conditions;
 • Cooling: Indoor temp.: 27°CDB, 19°CWB, Outdoor temp.: 35°CDB, Equivalent piping length: 7.5 m, Level difference: 0 m.
 • Heating: Indoor temp.: 20°CDB, Outdoor temp.: 7°CDB, 6°CWB, Equivalent piping length: 7.5 m, Level difference: 0 m.
 • Sound level: Anechoic chamber conversion value, measured at a point 1 m in front of the unit at a height of 1.5 m.
 During actual operation, these values are normally somewhat higher as a result of ambient conditions.

Outdoor Units

RHXYQ-AYL

Heat Pump

MODEL			RHXYQ38AYL	RHXYQ40AYL	RHXYQ42AYL	RHXYQ44AYL	RHXYQ46AYL	RHXYQ48AYL	RHXYQ50AYL	RHXYQ52AYL	RHXYQ54AYL	RHXYQ56AYL	RHXYQ58AYL	RHXYQ60AYL	RHXYQ62AYL	RHXYQ64AYL	RHXYQ66AYL		
Combination units			RHXYQ16AYL	RHXYQ18AYL	RHXYQ20AYL	RHXYQ22AYL	RHXYQ8AYL	RHXYQ10AYL	RHXYQ12AYL	RHXYQ10AYL	RHXYQ10AYL	RHXYQ12AYL	RHXYQ14AYL	RHXYQ16AYL	RHXYQ18AYL	RHXYQ20AYL	RHXYQ22AYL		
			RHXYQ22AYL	RHXYQ22AYL	RHXYQ22AYL	RHXYQ22AYL	RHXYQ16AYL	RHXYQ16AYL	RHXYQ16AYL	RHXYQ20AYL	RHXYQ22AYL	RHXYQ22AYL	RHXYQ22AYL	RHXYQ22AYL	RHXYQ22AYL	RHXYQ22AYL	RHXYQ22AYL	RHXYQ22AYL	
Power supply			3-phase 4-wire system, 380 V, 60 Hz						3-phase 4-wire system, 380 V, 60 Hz										
Cooling capacity			kcal/h	91,200	95,500	101,000	106,000	111,000	115,000	120,000	125,000	130,000	134,000	140,000	144,000	149,000	154,000	158,000	
			Btu/h	362,000	379,000	399,000	420,000	440,000	457,000	478,000	495,000	515,000	532,000	556,000	573,000	590,000	611,000	628,000	
			kW	106	111	117	123	129	134	140	145	151	156	163	168	173	179	184	
Heating capacity			kcal/h	102,000	108,000	114,000	119,000	124,000	130,000	135,000	141,000	146,000	151,000	157,000	162,000	167,000	173,000	178,000	
			Btu/h	406,000	427,000	450,000	471,000	491,000	515,000	536,000	560,000	580,000	601,000	625,000	642,000	662,000	686,000	706,000	
			kW	119	125	132	138	144	151	157	164	170	176	183	188	194	201	207	
Power consumption			Cooling	kW	26.5	27.9	29.8	31.5	30.8	32.5	33.9	35.7	37.5	38.9	40.6	42.3	43.7	45.5	47.3
			Heating	kW	28.3	29.7	32.0	34.0	33.1	34.8	36.3	38.5	40.5	42.0	43.9	45.3	46.7	49.0	51.0
Capacity control			%	4-100	4-100	4-100	4-100	3-100	3-100	3-100	3-100	3-100	3-100	3-100	3-100	3-100	3-100		
Casing colour			Ivory White (5Y7.5/1)						Ivory White (5Y7.5/1)										
Compressor			Hermetically Sealed Scroll Type						Hermetically Sealed Scroll Type										
Type			Hermetically Sealed Scroll Type						Hermetically Sealed Scroll Type										
Motor output			kW	((4.6+5.0)×1)+ ((5.0+7.4)×1)	((4.9+5.8)×1)+ ((5.0+7.4)×1)	((5.0+7.4)×1)+ ((5.0+7.4)×1)	((5.0+7.4)×1)+ ((5.0+7.4)×1)	(4.5×1)+ ((4.6+5.0)×1)+ ((5.0+7.4)×1)	(5.7×1)+ ((4.6+5.0)×1)+ ((5.0+7.4)×1)	(6.9×1)+ ((4.6+5.0)×1)+ ((5.0+7.4)×1)	(5.7×1)+ ((5.0+7.4)×1)+ ((5.0+7.4)×1)	(5.7×1)+ ((5.0+7.4)×1)+ ((5.0+7.4)×1)	(6.9×1)+ ((5.0+7.4)×1)+ ((5.0+7.4)×1)	((4.1+4.4)×1)+ ((5.0+7.4)×1)+ ((5.0+7.4)×1)	((4.6+5.0)×1)+ ((5.0+7.4)×1)+ ((5.0+7.4)×1)	((4.9+5.8)×1)+ ((5.0+7.4)×1)+ ((5.0+7.4)×1)	((5.0+7.4)×1)+ ((5.0+7.4)×1)+ ((5.0+7.4)×1)	((5.0+7.4)×1)+ ((5.0+7.4)×1)+ ((5.0+7.4)×1)	
Airflow rate			m ³ /min	260+271	251+271	261+271	271+271	162+260+271	175+260+271	185+260+271	175+261+271	175+271+271	185+271+271	223+271+271	260+271+271	251+271+271	261+271+271	271+271+271	
Dimensions: (H×W×D)			mm	(1,657×1,240×765)+(1,657×1,240×765)				(1,657×930×765)+(1,657×1,240×765)+ (1,657×1,240×765)			(1,657×930×765)+(1,657×1,240×765)+ (1,657×1,240×765)			(1,657×1,240×765)+(1,657×1,240×765)+(1,657×1,240×765)					
Machine weight			kg	285+317	317+317		184+285+317	191+285+317	213+285+317	191+317+317		213+317+317	285+317+317		317+317+317				
Sound level			dB(A)	65	65	66	66	66	66	66	66	67	67	67	67	67	68	68	
Operation range			Cooling	°CDB						-5 to 43									
			Heating	°CWB						-20 to 15.5									
Refrigerant			R-410A						R-410A										
Type			R-410A						R-410A										
Charge			kg	6.9+8.6	8.6+8.6		5.0+6.9+8.6	6.0+6.9+8.6	6.9+6.9+8.6	6.0+8.6+8.6		6.9+8.6+8.6		8.6+8.6+8.6					
Piping connections			Liquid	mm	φ19.1 (Brazing Connection)	φ19.1 (Brazing Connection)	φ19.1 (Brazing Connection)	φ19.1 (Brazing Connection)	φ19.1 (Brazing Connection)	φ19.1 (Brazing Connection)	φ19.1 (Brazing Connection)	φ19.1 (Brazing Connection)	φ19.1 (Brazing Connection)	φ19.1 (Brazing Connection)	φ19.1 (Brazing Connection)	φ19.1 (Brazing Connection)	φ19.1 (Brazing Connection)	φ19.1 (Brazing Connection)	
			Gas	mm	φ38.1 (Brazing Connection)	φ38.1 (Brazing Connection)	φ38.1 (Brazing Connection)	φ38.1 (Brazing Connection)	φ38.1 (Brazing Connection)	φ38.1 (Brazing Connection)	φ38.1 (Brazing Connection)	φ38.1 (Brazing Connection)	φ38.1 (Brazing Connection)	φ41.3 (Brazing Connection)	φ41.3 (Brazing Connection)	φ41.3 (Brazing Connection)	φ41.3 (Brazing Connection)	φ41.3 (Brazing Connection)	φ41.3 (Brazing Connection)

Note: Specifications are based on the following conditions;

- Cooling: Indoor temp.: 27°CDB, 19°CWB, Outdoor temp.: 35°CDB, Equivalent piping length: 7.5 m, Level difference: 0 m.
- Heating: Indoor temp.: 20°CDB, Outdoor temp.: 7°CDB, 6°CWB, Equivalent piping length: 7.5 m, Level difference: 0 m.
- Sound level: Anechoic chamber conversion value, measured at a point 1 m in front of the unit at a height of 1.5 m. During actual operation, these values are normally somewhat higher as a result of ambient conditions.

Outdoor Units

RHXYQ-ATL

Heat Pump

MODEL			RHXYQ8ATL	RHXYQ10ATL	RHXYQ12ATL	RHXYQ14ATL	RHXYQ16ATL	RHXYQ18ATL	RHXYQ20ATL		RHXYQ22ATL	RHXYQ24ATL	RHXYQ26ATL	RHXYQ28ATL	RHXYQ30ATL	RHXYQ32ATL	RHXYQ34ATL	RHXYQ36ATL		
Combination units			-	-	-	-	-	-	-		-	RHXYQ12ATL	RHXYQ10ATL	RHXYQ12ATL	RHXYQ8ATL	RHXYQ10ATL	RHXYQ12ATL	RHXYQ14ATL		
Power supply			3-phase 3-wire system, 220 V, 60 Hz									3-phase 3-wire system, 220 V, 60 Hz								
Cooling capacity			kcal/h	19,300	24,100	28,800	34,400	38,700	43,000	48,200		50,700	57,600	62,800	67,500	70,000	74,800	79,600	85,100	
			Btu/h	76,400	95,500	114,000	136,000	154,000	171,000	191,000		201,000	229,000	249,000	268,000	278,000	297,000	316,000	338,000	
			kW	22.4	28.0	33.5	40.0	45.0	50.0	56.0		59.0	67.0	73.0	78.5	81.4	87.0	92.5	99.0	
Heating capacity			kcal/h	21,500	27,100	32,300	38,700	43,000	48,200	54,200		59,300	64,500	70,100	75,300	80,800	86,900	92,000	98,000	
			Btu/h	85,300	107,000	128,000	154,000	171,000	191,000	215,000		235,000	256,000	278,000	299,000	321,000	345,000	365,000	389,000	
			kW	25.0	31.5	37.5	45.0	50.0	56.0	63.0		69.0	75.0	81.5	87.5	94.0	101	107	114	
Power consumption			Cooling	kW	4.28	5.94	7.38	9.08	10.77	12.13	13.99		15.13	14.8	16.7	18.1	19.4	21.1	22.5	24.2
			Heating	kW	4.85	6.50	8.01	9.91	11.27	12.73	15.00		17.00	16.0	17.8	19.3	21.8	23.5	25.0	26.9
Capacity control			%	20-100	16-100	15-100	10-100	8-100			8-100	8-100	5-100	5-100	5-100	5-100	5-100	4-100		
Casing colour			Ivory White (5Y7.5/1)									Ivory White (5Y7.5/1)								
Compressor			Hermetically Sealed Scroll Type									Hermetically Sealed Scroll Type								
Motor output			kW	4.5×1	5.7×1	6.9×1	(4.1+4.4)×1	(4.6+5.0)×1	(4.9+5.8)×1	(5.0+7.4)×1		(5.0+7.4)×1	(6.9×1)+(6.9×1)	(5.7×1)+ ((4.6+5.0)×1)	(6.9×1)+ ((4.6+5.0)×1)	(4.5×1)+ ((5.0+7.4)×1)	(5.7×1)+ ((5.0+7.4)×1)	(6.9×1)+ ((5.0+7.4)×1)	((4.1+4.4)×1)+ ((5.0+7.4)×1)	
Airflow rate			m ³ /min	162	175	185	223	260	251	261		271	185+185	175+260	185+260	162+271	175+271	185+271	223+271	
Dimensions: (H×W×D)			mm	1,657×930×765				1,657×1,240×765				1,657×1,240×765	(1,657×930×765)+ (1,657×930×765)	(1,657×930×765)+(1,657×1,240×765)						(1,657×1,240×765)+ (1,657×1,240×765)
Machine weight			kg	184	191	213	285	285	317	317		317	213+213	191+285	213+285	184+317	191+317	213+317	285+317	
Sound level			dB(A)	57	58	60	60	60	61	62		63	63	62	63	64	64	65	65	
Operation range			Cooling	°CDB -5 to 43									°CDB -5 to 43							
			Heating	°CWB -20 to 15.5									°CWB -20 to 15.5							
Refrigerant			R-410A									R-410A								
Charge			kg	5.0	6.0	6.9			8.6				8.6	6.9+6.9	6.0+6.9	6.9+6.9	5.0+8.6	6.0+8.6	6.9+8.6	
Piping connections			Liquid	φ9.5 (Brazing Connection)		φ12.7 (Brazing Connection)			φ15.9 (Brazing Connection)				φ15.9 (Brazing Connection)	φ15.9 (Brazing Connection)	φ19.1 (Brazing Connection)	φ19.1 (Brazing Connection)	φ19.1 (Brazing Connection)	φ19.1 (Brazing Connection)	φ19.1 (Brazing Connection)	φ19.1 (Brazing Connection)
			Gas	φ19.1 (Brazing Connection)		φ22.2 (Brazing Connection)	φ25.4 (Brazing Connection)		φ28.6 (Brazing Connection)				φ28.6 (Brazing Connection)	φ28.6 (Brazing Connection)	φ31.8 (Brazing Connection)	φ31.8 (Brazing Connection)	φ31.8 (Brazing Connection)	φ31.8 (Brazing Connection)	φ31.8 (Brazing Connection)	φ31.8 (Brazing Connection)

Note: Specifications are based on the following conditions;
 • Cooling: Indoor temp.: 27°CDB, 19°CWB, Outdoor temp.: 35°CDB, Equivalent piping length: 7.5 m, Level difference: 0 m.
 • Heating: Indoor temp.: 20°CDB, Outdoor temp.: 7°CDB, 6°CWB, Equivalent piping length: 7.5 m, Level difference: 0 m.
 • Sound level: Anechoic chamber conversion value, measured at a point 1 m in front of the unit at a height of 1.5 m.
 During actual operation, these values are normally somewhat higher as a result of ambient conditions.

Outdoor Units

RHXYQ-ATL

Heat Pump

MODEL			RHXYQ38ATL	RHXYQ40ATL	RHXYQ42ATL	RHXYQ44ATL	RHXYQ46ATL	RHXYQ48ATL	RHXYQ50ATL	RHXYQ52ATL	RHXYQ54ATL	RHXYQ56ATL	RHXYQ58ATL	RHXYQ60ATL	RHXYQ62ATL	RHXYQ64ATL	RHXYQ66ATL		
Combination units			RHXYQ16ATL	RHXYQ18ATL	RHXYQ20ATL	RHXYQ22ATL	RHXYQ8ATL	RHXYQ10ATL	RHXYQ12ATL	RHXYQ10ATL	RHXYQ10ATL	RHXYQ12ATL	RHXYQ14ATL	RHXYQ16ATL	RHXYQ18ATL	RHXYQ20ATL	RHXYQ22ATL		
			RHXYQ22ATL	RHXYQ22ATL	RHXYQ22ATL	RHXYQ22ATL	RHXYQ16ATL	RHXYQ16ATL	RHXYQ16ATL	RHXYQ20ATL	RHXYQ22ATL	RHXYQ22ATL	RHXYQ22ATL	RHXYQ22ATL	RHXYQ22ATL	RHXYQ22ATL	RHXYQ22ATL	RHXYQ22ATL	
Power supply			3-phase 3-wire system, 220 V, 60 Hz						3-phase 3-wire system, 220 V, 60 Hz										
Cooling capacity			kcal/h	89,400	93,700	98,900	101,000	108,000	114,000	118,000	123,000	126,000	130,000	136,000	140,000	144,000	150,000	152,000	
			Btu/h	355,000	372,000	392,000	403,000	430,000	450,000	467,000	488,000	498,000	515,000	539,000	556,000	573,000	594,000	604,000	
			kW	104	109	115	118	126	132	137	143	146	151	158	163	168	174	177	
Heating capacity			kcal/h	102,000	108,000	114,000	119,000	124,000	130,000	135,000	141,000	146,000	151,000	157,000	162,000	167,000	173,000	178,000	
			Btu/h	406,000	427,000	450,000	471,000	491,000	515,000	536,000	560,000	580,000	601,000	625,000	642,000	662,000	686,000	706,000	
			kW	119	125	132	138	144	151	157	164	170	176	183	188	194	201	207	
Power consumption			Cooling	kW	25.9	27.3	29.1	30.3	30.2	31.8	33.3	35.1	36.2	37.6	39.3	41.0	42.4	44.3	45.4
			Heating	kW	28.3	29.7	32.0	34.0	33.1	34.8	36.3	38.5	40.5	42.0	43.9	45.3	46.7	49.0	51.0
Capacity control			%	4-100	4-100	4-100	4-100	3-100	3-100	3-100	3-100	3-100	3-100	3-100	3-100	3-100	3-100		
Casing colour			Ivory White (5Y7.5/1)						Ivory White (5Y7.5/1)										
Compressor			Hermetically Sealed Scroll Type						Hermetically Sealed Scroll Type										
Type			Hermetically Sealed Scroll Type						Hermetically Sealed Scroll Type										
Motor output			kW	((4.6+5.0)×1)+ ((5.0+7.4)×1)	((4.9+5.8)×1)+ ((5.0+7.4)×1)	((5.0+7.4)×1)+ ((5.0+7.4)×1)	((5.0+7.4)×1)+ ((5.0+7.4)×1)	(4.5×1)+ ((4.6+5.0)×1)+ ((5.0+7.4)×1)	(5.7×1)+ ((4.6+5.0)×1)+ ((5.0+7.4)×1)	(6.9×1)+ ((4.6+5.0)×1)+ ((5.0+7.4)×1)	(5.7×1)+ ((5.0+7.4)×1)+ ((5.0+7.4)×1)	(5.7×1)+ ((5.0+7.4)×1)+ ((5.0+7.4)×1)	(6.9×1)+ ((5.0+7.4)×1)+ ((5.0+7.4)×1)	((4.1+4.4)×1)+ ((5.0+7.4)×1)+ ((5.0+7.4)×1)	((4.6+5.0)×1)+ ((5.0+7.4)×1)+ ((5.0+7.4)×1)	((4.9+5.8)×1)+ ((5.0+7.4)×1)+ ((5.0+7.4)×1)	((5.0+7.4)×1)+ ((5.0+7.4)×1)+ ((5.0+7.4)×1)	((5.0+7.4)×1)+ ((5.0+7.4)×1)+ ((5.0+7.4)×1)	
Airflow rate			m ³ /min	260+271	251+271	261+271	271+271	162+260+271	175+260+271	185+260+271	175+261+271	175+271+271	185+271+271	223+271+271	260+271+271	251+271+271	261+271+271	271+271+271	
Dimensions: (H×W×D)			mm	(1,657×1,240×765)+(1,657×1,240×765)				(1,657×930×765)+(1,657×1,240×765)+ (1,657×1,240×765)			(1,657×930×765)+(1,657×1,240×765)+ (1,657×1,240×765)			(1,657×1,240×765)+(1,657×1,240×765)+(1,657×1,240×765)					
Machine weight			kg	285+317	317+317		184+285+317	191+285+317	213+285+317	191+317+317		213+317+317	285+317+317		317+317+317				
Sound level			dB(A)	65	65	66	66	66	66	66	66	67	67	67	67	67	68	68	
Operation range			Cooling	°CDB						-5 to 43									
			Heating	°CWB						-20 to 15.5									
Refrigerant			R-410A						R-410A										
Type			R-410A						R-410A										
Charge			kg	6.9+8.6	8.6+8.6		5.0+6.9+8.6	6.0+6.9+8.6	6.9+6.9+8.6	6.0+8.6+8.6		6.9+8.6+8.6		8.6+8.6+8.6					
Piping connections			Liquid	mm	φ19.1 (Brazing Connection)	φ19.1 (Brazing Connection)	φ19.1 (Brazing Connection)	φ19.1 (Brazing Connection)	φ19.1 (Brazing Connection)	φ19.1 (Brazing Connection)	φ19.1 (Brazing Connection)	φ19.1 (Brazing Connection)	φ19.1 (Brazing Connection)	φ19.1 (Brazing Connection)	φ19.1 (Brazing Connection)	φ19.1 (Brazing Connection)	φ19.1 (Brazing Connection)	φ19.1 (Brazing Connection)	
			Gas	mm	φ38.1 (Brazing Connection)	φ38.1 (Brazing Connection)	φ38.1 (Brazing Connection)	φ38.1 (Brazing Connection)	φ38.1 (Brazing Connection)	φ38.1 (Brazing Connection)	φ38.1 (Brazing Connection)	φ38.1 (Brazing Connection)	φ38.1 (Brazing Connection)	φ41.3 (Brazing Connection)	φ41.3 (Brazing Connection)	φ41.3 (Brazing Connection)	φ41.3 (Brazing Connection)	φ41.3 (Brazing Connection)	φ41.3 (Brazing Connection)

Note: Specifications are based on the following conditions;

- Cooling: Indoor temp.: 27°CDB, 19°CWB, Outdoor temp.: 35°CDB, Equivalent piping length: 7.5 m, Level difference: 0 m.
- Heating: Indoor temp.: 20°CDB, Outdoor temp.: 7°CDB, 6°CWB, Equivalent piping length: 7.5 m, Level difference: 0 m.
- Sound level: Anechoic chamber conversion value, measured at a point 1 m in front of the unit at a height of 1.5 m. During actual operation, these values are normally somewhat higher as a result of ambient conditions.

Outdoor Units

RXYQ-TYDN

Heat Pump

HP		7.5 HP	10 HP	12.5 HP	15 HP	17.5 HP			20 HP	22.5 HP	25 HP	27.5 HP	30 HP	
MODEL		RXYQ72TYDN	RXYQ96TYDN	RXYQ120TYDN	RXYQ144TYDN	RXYQ168TYDN			RXYQ192TYDN	RXYQ216TYDN	RXYQ240TYDN	RXYQ264TYDN	RXYQ288TYDN	
Combination units		-	-	-	-	-			RXYQ72TYDN RXYQ120TYDN	RXYQ96TYDN RXYQ120TYDN	RXYQ120TYDN RXYQ120TYDN	RXYQ120TYDN RXYQ144TYDN	RXYQ144TYDN RXYQ144TYDN	
Power supply		3-phase 3-wire system, 460 V, 60 Hz						3-phase 3-wire system, 460 V, 60 Hz						
Cooling capacity	Btu/h	72,000	96,000	120,000	144,000	168,000			192,000	216,000	240,000	264,000	288,000	
	kW	21.1	28.1	35.2	42.2	49.2			56.3	63.3	70.4	77.4	84.4	
Heating capacity	Btu/h	81,000	108,000	135,000	162,000	188,000			216,000	243,000	270,000	297,000	324,000	
	kW	23.7	31.7	39.6	47.5	55.1			63.3	71.3	79.2	87.1	95.0	
Power consumption	Cooling	kW	4.54	5.85	8.03	9.96	13.1			12.6	13.9	16.1	18.0	19.9
	Heating	kW	5.16	6.34	8.54	9.98	12.3			13.7	14.9	17.1	18.5	20.0
Capacity control		%	20 - 100	16 - 100	15 - 100	11 - 100	10 - 100			17 - 100	15 - 100	15 - 100	13 - 100	11 - 100
Casing colour		Ivory white (5Y7.5/1)						Ivory white (5Y7.5/1)						
Compressor	Type	Hermetically Sealed Scroll Type						Hermetically Sealed Scroll Type						
	Motor output	kW	3.4×1	4.1×1	5.2×1	(2.9×1)+(3.3×1)	(3.6×1)+(3.7×1)			(3.4×1)+(5.2×1)	(4.1×1)+(5.2×1)	(5.2×1)+(5.2×1)	(5.2×1)+(2.9×1+3.3×1)	(2.9×1+3.3×1)+(2.9×1+3.3×1)
Airflow rate		m ³ /min	157	165	178	233	233			157+178	165+178	178+178	178+233	233+233
Dimensions: (HxWxD)		mm	1,694×932×767	1,694×1,242×767						(1,694×932×767)+(1,694×1,242×767)	(1,694×1,242×767)+(1,694×1,242×767)			
Machine weight		kg	205	251	252	322	322			205+252	251+252	252+252	252+322	322+322
Sound level		dB(A)	58	61	61	64	65			63	64	64	66	67
Operation range	Cooling	°CDB	-5 to 43						-5 to 43					
	Heating	°CWB	-20 to 15.5						-20 to 15.5					
Refrigerant	Type	R-410A						R-410A						
	Charge	kg	5.9	10.3	10.4	8.2	7.8			5.9+10.4	10.3+10.4	10.4+10.4	10.4+8.2	8.2+8.2
Piping connections	Liquid	mm	φ9.5 (Brazeing Connection)		φ12.7 (Brazeing Connection)		φ15.9 (Brazeing Connection)			φ15.9 (Brazeing Connection)			φ19.1 (Brazeing Connection)	
	Gas	mm	φ19.1 (Brazeing Connection)	φ22.2 (Brazeing Connection)	φ28.6 (Brazeing Connection)					φ28.6 (Brazeing Connection)		φ34.9 (Brazeing Connection)		

Note: Specifications are based on the following conditions;
 • Cooling: Indoor temp.: 27°CDB, 19°CWB, Outdoor temp.: 35°CDB, Equivalent piping length: 7.5 m, Level difference: 0 m.
 • Heating: Indoor temp.: 20°CDB, Outdoor temp.: 7°CDB, 6°CWB, Equivalent piping length: 7.5 m, Level difference: 0 m.
 • Sound level: Anechoic chamber conversion value, measured at a point 1 m in front of the unit at a height of 1 m.
 During actual operation, these values are normally somewhat higher as a result of ambient conditions.

Outdoor Units

RXYQ-TYDN

Heat Pump

HP		32.5 HP	35 HP	37.5 HP	40 HP	42.5 HP			45 HP	47.5 HP	50 HP	52.5 HP		
MODEL		RXYQ312TYDN	RXYQ336TYDN	RXYQ360TYDN	RXYQ384TYDN	RXYQ408TYDN			RXYQ432TYDN	RXYQ456TYDN	RXYQ480TYDN	RXYQ504TYDN		
Combination units		RXYQ144TYDN	RXYQ168TYDN	RXYQ120TYDN	RXYQ96TYDN	RXYQ96TYDN			RXYQ144TYDN	RXYQ144TYDN	RXYQ144TYDN	RXYQ168TYDN		
		RXYQ168TYDN	RXYQ168TYDN	RXYQ120TYDN	RXYQ120TYDN	RXYQ144TYDN			RXYQ144TYDN	RXYQ144TYDN	RXYQ168TYDN	RXYQ168TYDN		
		-	-	RXYQ120TYDN	RXYQ168TYDN	RXYQ168TYDN			RXYQ144TYDN	RXYQ168TYDN	RXYQ168TYDN	RXYQ168TYDN		
Power supply		3-phase 3-wire system, 460 V, 60 Hz						3-phase 3-wire system, 460 V, 60 Hz						
Cooling capacity		Btu/h	312,000	336,000	360,000	384,000	408,000			432,000	456,000	480,000	504,000	
		kW	91.4	98.4	105	112	119			126	133	140	147	
Heating capacity		Btu/h	350,000	376,000	405,000	431,000	458,000			486,000	512,000	538,000	564,000	
		kW	102	110	118	126	134			142	150	157	165	
Power consumption	Cooling	kW	23.1	26.2	24.1	27.0	28.9			29.9	33.0	36.2	39.3	
	Heating	kW	22.3	24.6	25.6	27.2	28.6			29.9	32.3	34.6	36.9	
Capacity control		%	10 - 100	10 - 100	15 - 100	13 - 100	12 - 100			11 - 100	10 - 100	10 - 100		
Casing colour		Ivory white (5Y7.5/1)						Ivory white (5Y7.5/1)						
Compressor		Type	Hermetically Sealed Scroll Type						Hermetically Sealed Scroll Type					
		Motor output	kW	(2.9×1+3.3×1)+ (3.6×1+3.7×1)	(3.6×1+3.7×1)+ (3.6×1+3.7×1)	(5.2×1)+(5.2×1)+ (5.2×1)	(4.1×1)+(5.2×1)+ (3.6×1+3.7×1)	(4.1×1)+ (2.9×1+3.3×1)+ (3.6×1+3.7×1)			(2.9×1+3.3×1)+ (2.9×1+3.3×1)+ (2.9×1+3.3×1)	(2.9×1+3.3×1)+ (2.9×1+3.3×1)+ (3.6×1+3.7×1)	(2.9×1+3.3×1)+ (3.6×1+3.7×1)+ (3.6×1+3.7×1)	(3.6×1+3.7×1)+ (3.6×1+3.7×1)+ (3.6×1+3.7×1)
Airflow rate		m ³ /min	233+233	233+233	178+178+178	165+178+233	165+233+233			233+233+233	233+233+233	233+233+233	233+ 233+233	
Dimensions: (H×W×D)		mm	(1,694×1,242×767)+ (1,694×1,242×767)		(1,694×1,242×767)+(1,694×1,242×767)+ (1,694×1,242×767)			(1,694×1,242×767)+(1,694×1,242×767)+(1,694×1,242×767)						
Machine weight		kg	322+322	322+322	252+252+252	251+252+322	251+322+322			322+322+322	322+322+322	322+322+322	322+322+322	
Sound level		dB(A)	68	68	66	68	68			69	69	69	70	
Operation range		Cooling	°CDB -5 to 43						°CDB -5 to 43					
		Heating	°CWB -20 to 15.5						°CWB -20 to 15.5					
Refrigerant		Type	R-410A						R-410A					
		Charge	kg	8.2+7.8	7.8+7.8	10.4+10.4+10.4	10.3+10.4+7.8	10.3+8.2+7.8			8.2+8.2+8.2	8.2+8.2+7.8	8.2+7.8+7.8	7.8+7.8+7.8
Piping connections		Liquid	mm φ19.1 (Brazeing Connection)						mm φ19.1 (Brazeing Connection)					
		Gas	mm φ34.9 (Brazeing Connection)			mm φ41.3 (Brazeing Connection)			mm φ41.3 (Brazeing Connection)					

Note: Specifications are based on the following conditions:
 • Cooling: Indoor temp.: 27°CDB, 19°CWB, Outdoor temp.: 35°CDB, Equivalent piping length: 7.5 m, Level difference: 0 m.
 • Heating: Indoor temp.: 20°CDB, Outdoor temp.: 7°CDB, 6°CWB, Equivalent piping length: 7.5 m, Level difference: 0 m.
 • Sound level: Anechoic chamber conversion value, measured at a point 1 m in front of the unit at a height of 1 m.
 During actual operation, these values are normally somewhat higher as a result of ambient conditions.

Indoor Units

Ceiling Mounted Cassette (Round Flow with Sensing) Type

No.	Item	Type	FXFSQ25A	FXFSQ32A	FXFSQ40A	FXFSQ50A	FXFSQ63A	FXFSQ71A
1	Decoration panel		BYCSP125BW1					
2	Panel spacer		KDBP55H160FA					
3	Long life replacement filter	Non-woven type	KAFP551K160					

No.	Item	Type	FXFSQ80A	FXFSQ90A	FXFSQ100A	FXFSQ112A	FXFSQ125A	
1	Decoration panel		BYCSP125BW1					
2	Panel spacer		KDBP55H160FA					
3	Long life replacement filter	Non-woven type	KAFP551K160					

Ceiling Mounted Cassette (Round Flow) Type

No.	Item	Type	FXFQ25A	FXFQ32A	FXFQ40A	FXFQ50A	FXFQ63A	FXFQ71A
1	Decoration panel		BYCP125K-W1					
2	Panel spacer		KDBP55H160FA					
3	Long life replacement filter	Non-woven type	KAFP551K160					

No.	Item	Type	FXFQ80A	FXFQ90A	FXFQ100A	FXFQ112A	FXFQ125A	
1	Decoration panel		BYCP125K-W1					
2	Panel spacer		KDBP55H160FA					
3	Long life replacement filter	Non-woven type	KAFP551K160					

Ceiling Mounted Cassette (Compact Multi Flow) Type

No.	Item	Type	FXZQ20M	FXZQ25M	FXZQ32M	FXZQ40M	FXZQ50M	
1	Decoration panel		BYFQ60B3W1					
2	Sealing material of air discharge outlet		KDBH44BA60					
3	Panel spacer		KDBQ44BA60A					
4	Replacement long-life filter		KAFQ441BA60					
5	Fresh air intake kit	Direct installation type	KDDQ44XA60					

Ceiling Mounted Cassette (Double Flow) Type

No.	Item	Type	FXCQ20M FXCQ25M FXCQ32M	FXCQ40M	FXCQ50M	FXCQ63M	FXCQ80M	FXCQ125M
1	Decoration panel		BYBC32G-W1	BYBC50G-W1		BYBC63G-W1	BYBC32G-W1	
2	Filter related	High efficiency filter 65% ★1	KAFJ532G36		KAFJ532G80		KAFJ532G160	
		High efficiency filter 90% ★1	KAFJ533G36		KAFJ533G80		KAFJ533G160	
		Filter chamber bottom suction	KDDFJ53G36		KDDFJ53G80		KDDFJ53G160	
		Long life replacement filter	KAFJ531G36		KAFJ531G80		KAFJ531G160	

Note: ★1 Filter chamber is required if installing high efficiency filter.

Ceiling Mounted Cassette (Single Flow) Type*

No.	Item	Type	FXEQ20A	FXEQ25A	FXEQ32A	FXEQ40A	FXEQ50A	FXEQ63A	
1	Decoration panel		BYEP40AW1				BYEP63AW1		

* This is preliminary information as the product is not released yet. Please contact your local sales office for details.

Slim Ceiling Mounted Duct Type (700 mm width type)

No.	Item	Type	FXDQ20PB	FXDQ25PB	FXDQ32PB
1	Insulation kit for high humidity		KDT25N32		

Slim Ceiling Mounted Duct Type (900/1,100 mm width type)

No.	Item	Type	FXDQ40NB	FXDQ50NB	FXDQ63NB
1	Insulation kit for high humidity		KDT25N50		KDT25N63

Ceiling Mounted Duct Type

No.	Item	Type	FXMQ20A FXMQ25A FXMQ32A	FXMQ36A FXMQ40A	FXMQ50A FXMQ56A FXMQ63A FXMQ80A	FXMQ100A FXMQ125A FXMQ140P	FXMQ200MA FXMQ250MA	
1	Drain pump kit		—					KDU30L250VE
2	High efficiency filter	65%	KAF372AA36	KAF372AA56	KAF372AA80	KAF372AA160	KAFJ372L280	
		90%	KAF373AA36	KAF373AA56	KAF373AA80	KAF373AA160	KAFJ373L280	
3	Filter chamber		KDDF37AA36	KDDF37AA56	KDDF37AA80	KDDF37AA160	KDJ3705L280	
4	Long life replacement filter		KAF371AA36	KAF371AA56	KAF371AA80	KAF371AA160	KAFJ371L280	
5	Long life filter chamber kit		KAF375AA36	KAF375AA56	KAF375AA80	KAF375AA160		
6	Service panel	White	KTBJ25K36W	KTBJ25K56W	KTBJ25K80W	KTBJ25K160W	—	
		Fresh white	KTBJ25K36F	KTBJ25K56F	KTBJ25K80F	KTBJ25K160F		
		Brown	KTBJ25K36T	KTBJ25K56T	KTBJ25K80T	KTBJ25K160T		
7	Air discharge adaptor		KDAJ25K36A	KDAJ25K56A	KDAJ25K71A	KDAJ25K140A		

Indoor Units

4-Way Flow Ceiling Suspended Type

No.	Item	Type	FXUQ71A	FXUQ100A
1	Sealing member of air discharge outlet		KDBHP49B140	
2	Decoration panel for air discharge		KDBTP49B140	
3	Replacement long-life filter		KAFP551K160	

Ceiling Suspended Type

No.	Item	Type	FXHQ32MA	FXHQ63MA	FXHQ100MA
1	Drain pump kit		KDU50N60VE	KDU50N125VE	
2	Replacement long-life filter (Resin net)		KAF501DA56	KAF501DA80	KAF501DA112
3	L-type piping kit (for upward direction)		KHFP5MA63		

Wall Mounted Type

No.	Item	Type	FXAQ20P	FXAQ25P	FXAQ32P	FXAQ40P	FXAQ50P	FXAQ63P
1	Drain pump kit		K-KDU572EVE					

Floor Standing Type

No.	Item	Type	FXLQ20MA	FXLQ25MA	FXLQ32MA	FXLQ40MA	FXLQ50MA	FXLQ63MA
1	Long life replacement filter		KAFJ361K28	KAFJ361K45		KAFJ361K71		

Concealed Floor Standing Type

No.	Item	Type	FXNQ20MA	FXNQ25MA	FXNQ32MA	FXNQ40MA	FXNQ50MA	FXNQ63MA
1	Long life replacement filter		KAFJ361K28	KAFJ361K45		KAFJ361K71		

Outdoor Units

RHXYQ-A

No.	Item	Type	RHXYQ8A RHXYQ10A	RHXYQ12A RHXYQ14A RHXYQ16A	RHXYQ18A RHXYQ20A RHXYQ22A
1	Distributive piping	REFNET joint	KHRP26A22T KHRP26A33T	KHRP26A22T KHRP26A33T KHRP26A72T	

No.	Item	Type	RHXYQ24A RHXYQ26A RHXYQ28A RHXYQ30A	RHXYQ32A RHXYQ34A RHXYQ36A RHXYQ38A	RHXYQ40A RHXYQ42A RHXYQ44A
1	Distributive piping	REFNET joint	KHRP26A22T, KHRP26A33T KHRP26A72T, KHRP26A73T		
2	Outdoor unit multi connection piping kit		BHFP22P100		
3	Pipe size reducer		KHRP26M73TP		

No.	Item	Type	RHXYQ46A RHXYQ48A RHXYQ50A RHXYQ52A	RHXYQ54A RHXYQ56A RHXYQ58A RHXYQ60A	RHXYQ62A RHXYQ64A RHXYQ66A
1	Distributive piping	REFNET joint	KHRP26A22T, KHRP26A33T KHRP26A72T, KHRP26A73T		
2	Outdoor unit multi connection piping kit		BHFP22P151		
3	Pipe size reducer		KHRP26M73TP		

RXYQ-T

No.	Item	Type	RXYQ72T RXYQ96T	RXYQ120T RXYQ144T RXYQ168T
1	Distributive piping	REFNET header	KHRP26M22H, (Max. 4 branch) KHRP26M33H, (Max. 8 branch)	KHRP26M22H, KHRP26M33H, KHRP26M72H (Max. 4 branch) (Max. 8 branch) (Max. 8 branch)
		REFNET joint	KHRP26A22T KHRP26A33T	KHRP26A22T, KHRP26A33T, KHRP26M72TU

No.	Item	Type	RXYQ192T RXYQ216T RXYQ240T RXYQ264T RXYQ288T RXYQ312T RXYQ336T	RXYQ360T RXYQ384T RXYQ408T RXYQ432T RXYQ456T RXYQ480T RXYQ504T
1	Distributive piping	REFNET header	KHRP26M22H, KHRP26M33H, (Max. 4 branch) (Max. 8 branch) KHRP26M72H, KHRP26M73HU (Max. 8 branch) (Max. 8 branch)	
		REFNET joint	KHRP26A22T, KHRP26A33T, KHRP26M72TU, KHRP26M73TU	
2	Outdoor unit multi connection piping kit		BHFP22P100U	BHFP22P151U

Control System

Operation Control System Optional Accessories

No.	Item	Type	FXFSQ-A	FXFQ-A	FXZQ-M	FXCQ-M
1	Remote controller	Wireless	—	BRC7F634F	BRC7E530W	BRC7C62
2	Navigation remote controller (Wired remote controller)			Note 7 BRC1E62		
3	Simplified remote controller (Exposed type)					
4	Remote controller for hotel use (Concealed type)					
5	Adaptor for wiring		—	—	★KRP1BA57	★KRP1B61
6-1	Wiring adaptor for electrical appendices (1)		—	—	★KRP2A62	★KRP2A61
6-2	Wiring adaptor for electrical appendices (2)		—	—	★KRP4AA53	★KRP4AA51
7	Remote sensor (for indoor temperature)		KRCS01-4B		KRCS01-1B	
8	Installation box for adaptor PCB☆		—	—	Note 4, 6 KRP1BA101	Note 2, 3 KRP1B96
9	External control adaptor for outdoor unit		—	—	★DTA104A62	★DTA104A61
10	Adaptor for multi tenant		—	—		

No.	Item	Type	FXEQ-A	FXDQ-PB FXDQ-NB	FXMQ-A FXMQ-P	FXMQ-MA
1	Remote controller	Wireless	—	BRC4C65		BRC4C62
2	Navigation remote controller (Wired remote controller)		BRC1F61	Note 7 BRC1E62		
3	Simplified remote controller (Exposed type)		—	BRC2C51		
4	Remote controller for hotel use (Concealed type)		—	BRC3A61		
5	Adaptor for wiring		—	★KRP1B56	★KRP1C64	KRP1B61
6-1	Wiring adaptor for electrical appendices (1)		—	★KRP2A53	★KRP2A61	KRP2A61
6-2	Wiring adaptor for electrical appendices (2)		—	★KRP4A54	★KRP4AA51	KRP4AA51
7	Remote sensor (for indoor temperature)		KRCS01-4B	KRCS01-1B	KRCS01-4B	KRCS01-1B
8	Installation box for adaptor PCB☆		—	Note 4, 6 KRP1BA101	Note 2, 3 KRP4A96	—
9	External control adaptor for outdoor unit		—	★DTA104A53	★DTA104A61	DTA104A61
10	Adaptor for multi tenant		—	—	★DTA114A61	—

No.	Item	Type	FXUQ-A	FXHQ-MA	FXAQ-P	FXLQ-MA FXNQ-MA
1	Remote controller	Wireless	BRC7CB58	BRC7EA63W	BRC7EA618	BRC4C62
2	Navigation remote controller (Wired remote controller)			Note 7 BRC1E62		
3	Simplified remote controller (Exposed type)		—			BRC2C51
4	Remote controller for hotel use (Concealed type)		—			BRC3A61
5	Adaptor for wiring		—	KRP1BA54	—	KRP1B61
6-1	Wiring adaptor for electrical appendices (1)		—	★KRP2A62	★KRP2A61	KRP2A61
6-2	Wiring adaptor for electrical appendices (2)		★KRP4AA53	★KRP4AA52	★KRP4AA51	KRP4AA51
7	Remote sensor (for indoor temperature)		KRCS01-4B		KRCS01-1B	
8	Installation box for adaptor PCB☆		KRP1BA97	Note 3 KRP1CA93	Note 2, 3 KRP4AA93	—
9	External control adaptor for outdoor unit		—	★DTA104A62	★DTA104A61	DTA104A61
10	Adaptor for multi tenant		—	—	★DTA114A61	—

- Notes: 1. Installation box ☆ is necessary for each adaptor marked ★.
 2. Up to 2 adaptors can be fixed for each installation box.
 3. Only one installation box can be installed for each indoor unit.
 4. Up to 2 installation boxes can be installed for each indoor unit.
 5. Installation box ☆ is necessary for second adaptor.
 6. Installation box ☆ is necessary for each adaptor.
 7. Individual airflow direction, auto airflow rate and sensing sensor control can be set only via wired remote controller BRC1E62. Cannot be set via other remote controllers. Available functions depend on the type of indoor unit.

System Configuration

No.	Item	Model No.	Function
1	Residential central remote controller	Note 2 DCS303A51	• Up to 16 groups of indoor units (128 units) can be easily controlled using the large LCD panel. ON/OFF, temperature settings and scheduling can be controlled individually for indoor units.
2	Central remote controller	DCS302CA61	• Up to 64 groups of indoor units(128 units) can be connected, and ON/OFF, temperature setting and monitoring can be accomplished individually or simultaneously. Connectable up to 2 controllers in one system.
2-1	Electrical box with earth terminal (3 blocks)	KJB311AA	
3	Unified ON/OFF controller	DCS301BA61	• Up to 16 groups of indoor units(128 units) can be turned, ON/OFF individually or simultaneously, and operation and malfunction can be displayed. Can be used in combination with up to 8 controllers.
3-1	Electrical box with earth terminal (2 blocks)	KJB212AA	
3-2	Noise filter (for electromagnetic interface use only)	KEK26-1A	
4	Schedule timer	DST301BA61	• Programmed time weekly schedule can be controlled by unified control for up to 64 groups of indoor units (128 units). Can turn units ON/OFF twice per day.
5	Interface adaptor for SkyAir-series	Note 3 ★DTA112BA51	• Adaptors required to connect products other than those of the VRV System to the high-speed DIII-NET communication system adopted for the VRV System.
6	Central control adaptor kit	For UAT(Y)-K(A), FD-K ★DTA107A55	
7	Wiring adaptor for other air-conditioner	★DTA103A51	* To use any of the above optional controllers, an appropriate adaptor must be installed on the product unit to be controlled.
8	DIII-NET Expander Adaptor	DTA109A51	• Up to 1024 units can be centrally controlled in 64 different groups. • Wiring restrictions (max. length: 1,000m, total wiring length: 2,000m, max. number of branches: 16) apply to each adaptor.
8-1	Mounting plate	KRP4A92	• Fixing plate for DTA109A51

- Note: 1. Installation box for ★ adaptor must be obtained locally.
 2. For residential use only. Cannot be used with other centralised control equipment.
 3. No adaptor is required for some indoor units.

Building Management System

No.	Item	Model No.	Function
1	intelligent Touch Controller	Basic Hardware intelligent Touch Controller	DCS601C51 • Air-Conditioning management system that can be controlled by a compact all-in-one unit.
1-1		Option Hardware DIII-NET plus adaptor	DCS601A52 • Additional 64 groups (10 outdoor units) is possible.
1-2	Electrical box with earth terminal (4 blocks)		KJB411A • Wall embedded switch box.
2	intelligent Touch Manager	Basic Hardware intelligent Touch Manager	DCM601A51 • Air-conditioning management system that can be controlled by touch screen.
2-1		Hardware iTM plus adaptor	DCM601A52 • Additional 64 groups (10 outdoor units) is possible. Max. 7 iTM plus adaptors can be connected to intelligent Touch Manager.
2-2		Option Software iTM power proportional distribution	DCM002A51 • Power consumption of indoor units are calculated based on operation status of the indoor unit and outdoor unit power consumption measured by kWh metre.
2-3		iTM energy navigator	DCM008A51 • Building energy consumption is visualised . Wasted air-conditioning energy can be found out .
2-4		BACnet client	DCM009A51 • BACnet equipment can be managed by intelligent Touch Manager.
2-5	HTTP Interface		DCM007A51 • Interface for intelligent Touch Manager by HTTP
2-6	Di unit		DEC101A51 • 8 pairs based on a pair of ON/OFF input and abnormality input.
2-7	Dio unit		DEC102A51 • 4 pairs based on a pair of ON/OFF input and abnormality input.
3	*1 Interface for use in BACnet®		DMS502B51 • Interface unit to allow communications between VRV and BMS. Operation and monitoring of air-conditioning systems through BACnet® communication.
3-1	Optional DIII board		DAM411B51 • Expansion kit, installed on DMS502B51, to provide 2 more DIII-NET communication ports. Not usable independently.
3-2	Optional Di board		DAM412B51 • Expansion kit, installed on DMS502B51, to provide 16 more wattmeter pulse input points. Not usable independently.
4	*2 Interface for use in LONWORKS®		DMS504B51 • Interface unit to allow communications between VRV and BMS. Operation and monitoring of air-conditioning systems through LonWorks® communication.
5	Home Automation Interface Adaptor		DTA116A51 • Use of the Modbus protocol enables the connection of the VRV system with a variety of home automation systems from other manufacturers.
6	Contact/ analogue signal	Unification adaptor for computerised control	★DCS302A52 • Interface between the central monitoring board and central control units.

- Notes: *1. BACnet® is a registered trademark of American Society of Heating, Refrigerating and Air-Conditioning Engineers (ASHRAE).
 *2. LonWorks® is a trademark of Echelon Corporation registered in the United States and other countries.
 *3. Installation box for ★ adaptor must be obtained locally.

Individual Control Systems

Navigation remote controller (Wired remote controller) (Option)

Clear display

•Dot matrix display

- A combination of fine dots enables various icons. Large text display is easy to see.

•Backlight display

- Backlight display helps operating in dark rooms.

Simple operation

•Large buttons and arrow keys

- Large buttons and arrow keys enable easy operation. Basic setting such as fan speed and temperature can be intuitively operated. For other settings just select the function from the menu list.

•Guide on display

- The display gives an explanation of each setting for easy operation.



BRC1E62



BRC1F61
(only for FXEQ series)

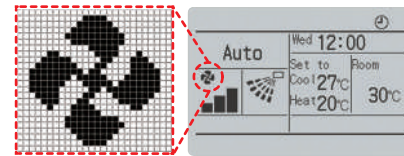

Energy saving

•Auto operation mode

- Until now only the temperature for one point could be set, but now the new remote controller (BRC1E62) allows the setting of both Cooling and Heating, and with the fan operation, mid-range temperatures are comfortable and operation is more energy efficient.

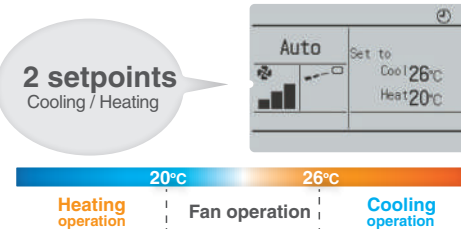

•Setpoint range set

- Saves energy by limiting the min. and max. set temperature.
- Avoids excessive cooling or heating.
- This function is convenient when the remote controller is installed at a place where any number of people may operate it.

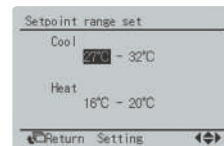

•Setpoint auto reset

- Even if the set temperature is changed, it returns to the preset temperature after a preset period of time.
- Period selectable from 30 min/60 min/90 min/120 min.

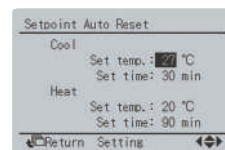

Restaurant sample

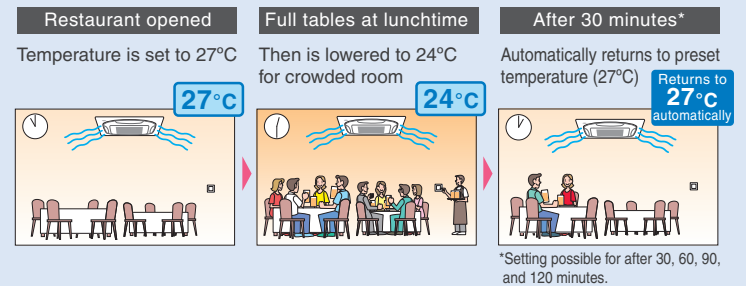

•Off timer

- Turns off the air conditioner after a preset period of time.
- Period can be preset from 30 to 180 minutes in 10-minute increments.

Convenience

•Setback (default:OFF) (*1)

- Maintains the room temperature in a specific range during unoccupied period by temporarily starting air conditioner that was turned OFF.

Ex) Setback temperature Cooling : 35°C Recovery differential Cooling : -2°C
When the room temperature goes above 35°C, the air conditioner starts operating in Cooling automatically. When room temperature reaches 33°C, the air conditioner returns OFF.

*1 Setback is not available for BRC1F61.

•Weekly schedule

- 5 actions per day can be scheduled for each day of the week.
- The holiday function will disable schedule timer for the days that have been set as holiday.
- 3 independent schedules can be set. (e.g. summer, winter, mid-season)

	Setback temperature	Recovery differential
Cooling	33 - 37°C	-2 - -8°C
Heating	10 - 15°C	+2 - +8°C

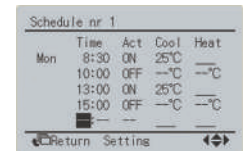

College classroom sample (a summer Monday case)

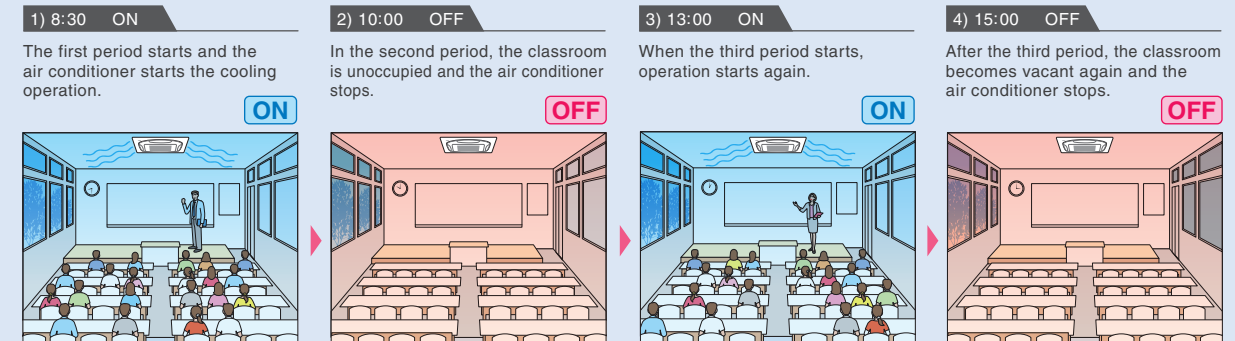

Comfort

•Individual airflow direction (*2)

- Airflow direction of each of the four air outlets can be controlled individually. (Positions 0 to 4, Swing, and No individual setting are selectable.)

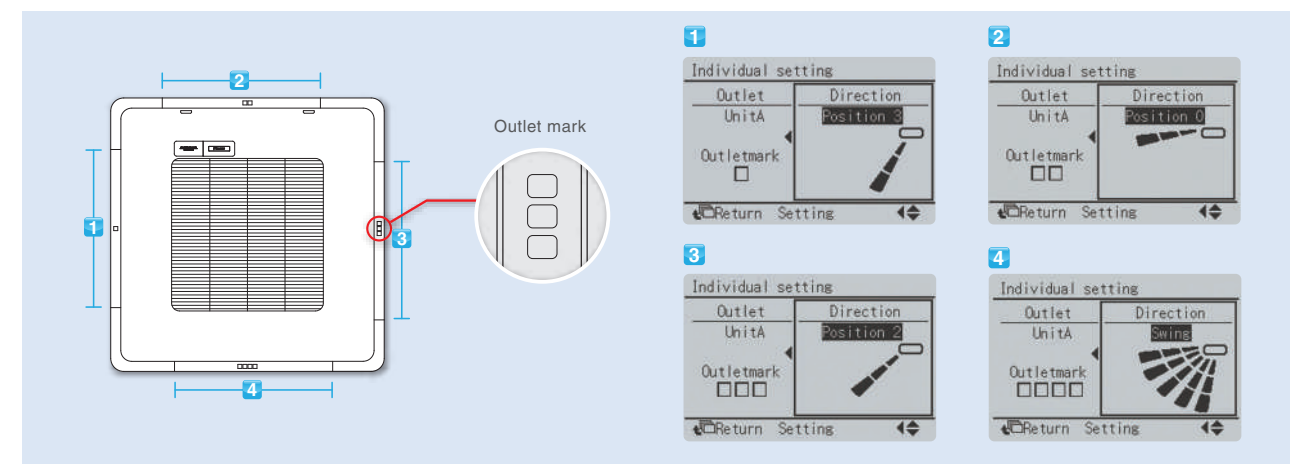

•Auto airflow rate (*2)

- Airflow rate is automatically controlled in accordance with the difference between room temperature and set temperature.

*2 Only available for VRV 4-Way Flow Ceiling Suspended type FXUQ series and Ceiling Mounted Cassette (Round Flow with Sensing) type FXFSQ series.

Individual Control Systems

The wired remote controller supports a wide range of control functions

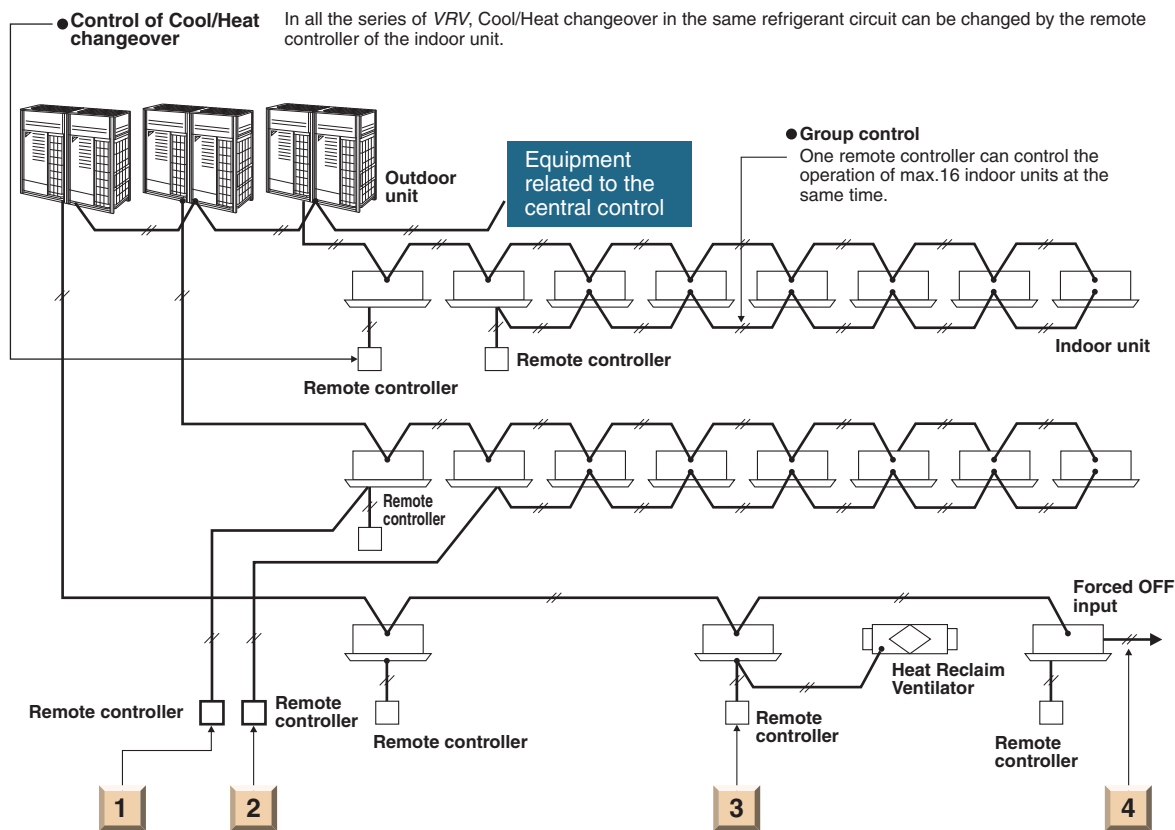

Wireless remote controller (Option)

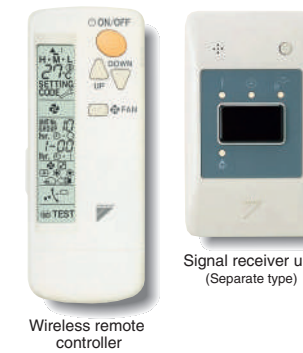

Wireless remote controller

Signal receiver unit (Separate type)



Signal receiver unit can be installed on the panel
ex. Ceiling Mounted Cassette (Round Flow) type FXFQ models

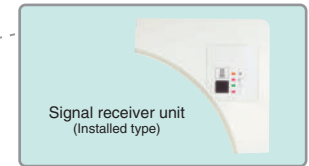

Signal receiver unit (Installed type)

* Wireless remote controller and signal receiver unit are sold as a set.
* Refer to page 55 for the name of each model.

Simplified remote controller (Option)

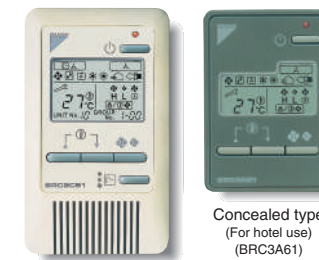

Exposed type (BRC2C51)

Concealed type (For hotel use) (BRC3A61)

- The remote controller has centralised its frequently used operation selectors and switches (on/off, operation mode, temperature setting and airflow volume), making itself suitable for use in hotel rooms or conference rooms.
- The exposed type remote controller is fitted with a thermostat sensor.



The concealed type remote controller smartly fits into a night table or console panel in a hotel room.

Wide variation of remote controllers for indoor units

	FXFSQ	FXFQ	FXZQ	FXCQ	FXEQ	FXDQ	FXMQ	FXUQ	FXHQ	FXAQ	FXL(N)Q
Navigation remote controller (Wired remote controller) (BRC1E62)	●	●	●	●		●	●	●	●	●	●
Navigation remote controller (Wired remote controller) (BRC1F61)					●						
Wireless remote controller* (Installed type signal receiver unit)		●	●	●				●	●	●	
Wireless remote controller* (Separate type signal receiver unit)						●	●				●
Simplified remote controller (Exposed type) (BRC2C51)						●	●				●
Simplified remote controller (Concealed type: for Hotel use) (BRC3A61)						●	●				●

* Refer to page 55 for the name of each model.

Integrated Building Monitoring System

The high speed transmission of DIII-NET enables more advanced control of the VRV system, providing you with enhanced comfort.

- DIII-NET Line
- BACnet®/Ethernet or LONWORKS® Network Communication Line
- - - Contact Signal Line
- RS485 Modbus Line

The DIII-NET system provides for:

- Close control and monitoring by integrating a wide variety of air-conditioners in the entire building.
- Saving the in-building cabling using non-polar, two-wire cables. Easier wiring work with tremendously fewer wiring errors.
- Additional setups readily up and running. An extendable cabling up to 2 km in total.
- Different control equipment flexibly joined in the system for hierarchical risk diversification.
- Daikin's total heat exchangers and other devices under integral control.

Controllers for Centralised Control

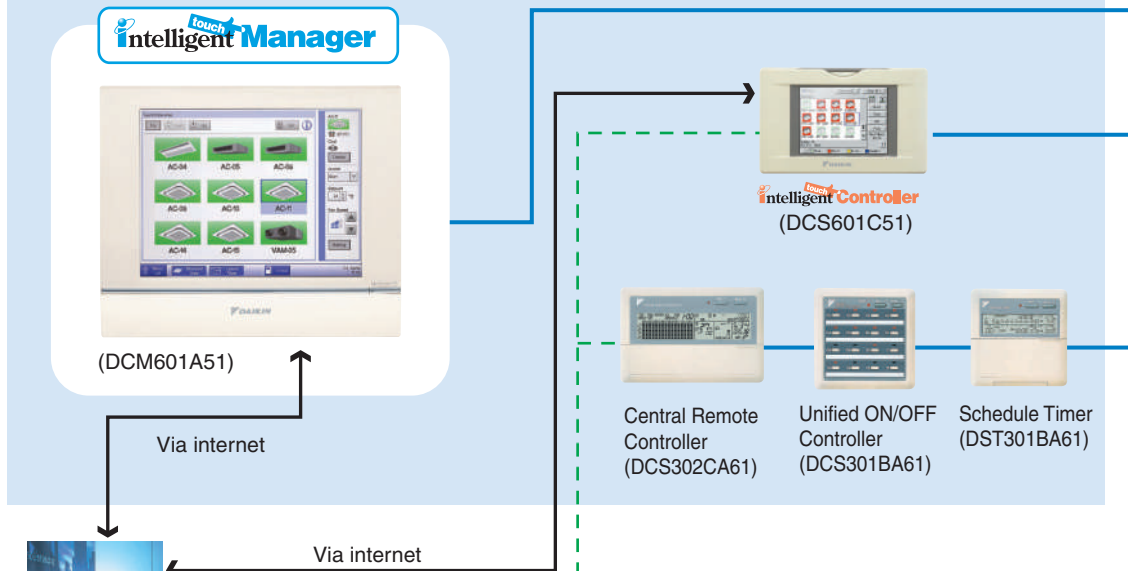

ACC Centre
Air Conditioning Network Service System
(There are restrictions in applicable areas and release times, therefore please consult us separately for details.)
(Optional Maintenance Service)

Home Automation Master Controller

BMS
(Obtain locally)

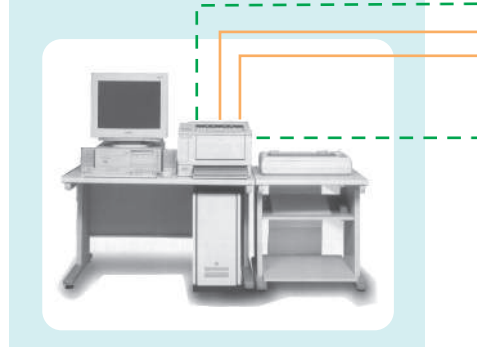

Control /Connection Interface

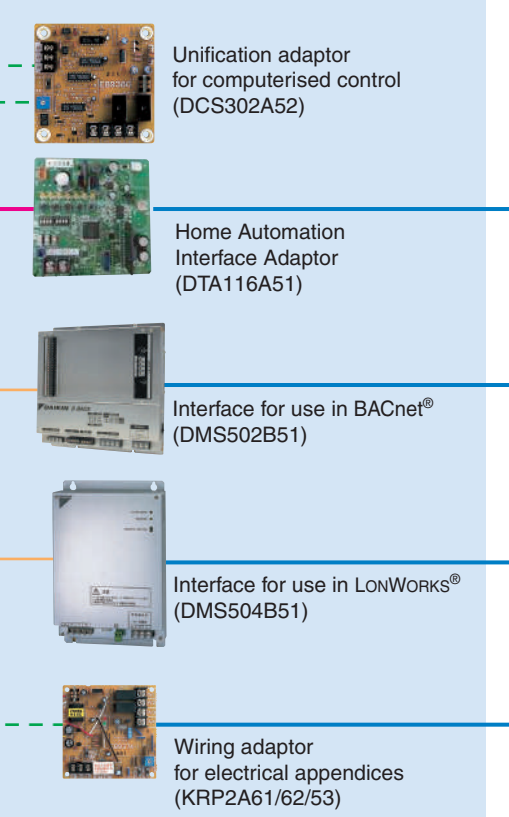

DIII-NET

(High Speed Multiple Transmission)

DIII-NET, Daikin's unique high speed multiple transmission system, links air conditioners and various other building equipment – in accordance with applications, scale and conditions – and transmits vast amounts of information between them.

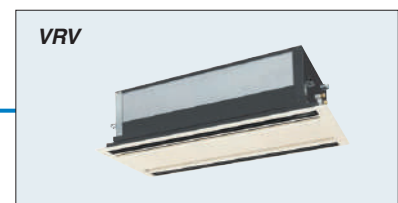
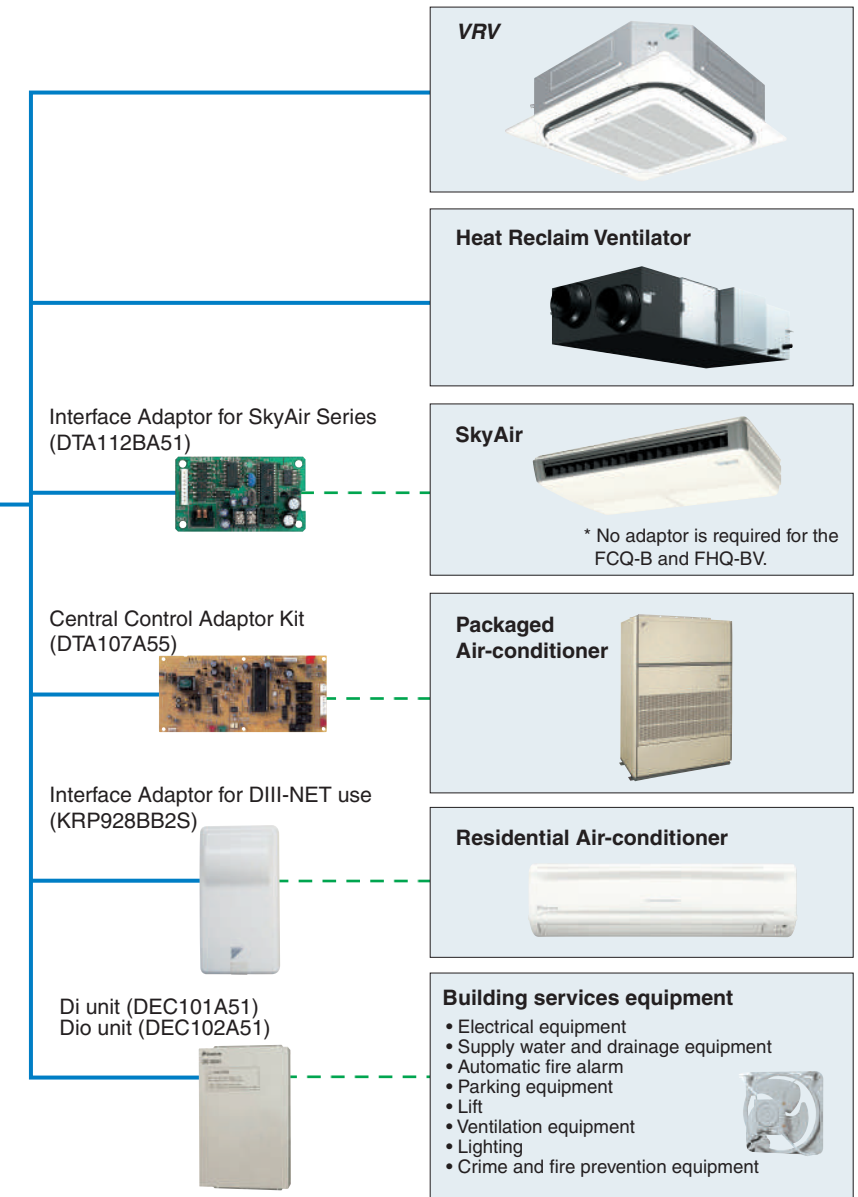

Caution:
Limitation may apply to some models and functions. Please contact your local sales office for details. Consultation is necessary before employing this control system. Please contact your local sales office before making a purchase.

Note: BACnet® is a registered trademark of American Society of Heating, Refrigerating and Air-Conditioning Engineers (ASHRAE). LONWORKS® is a trademark of Echelon Corporation registered in the United States and other countries.

Advanced Control Systems



intelligent Touch Manager maximises the advantages of VRV features

intelligent Touch Manager is an advanced multi-zone controller that provides the most cost-effective way to control and monitor the Daikin VRV system.

The 10.4" LCD touch screen is easy to use with three different screen views to include the floor plan layout view, icon view and list view and menus for system configurations.

It is also easy to use with standardized remote Web Access from your PC.

It can manage a total of 650 management points consisting of up to 512 Daikin indoor unit groups (up to 1024 indoor units) along with building equipment control / monitoring with Digital Inputs / Output (Di/Dio) , Analog Inputs / Output (Ai/Ao) and Pulse input (Pi) optional devices.

intelligent Touch Manager System Overview

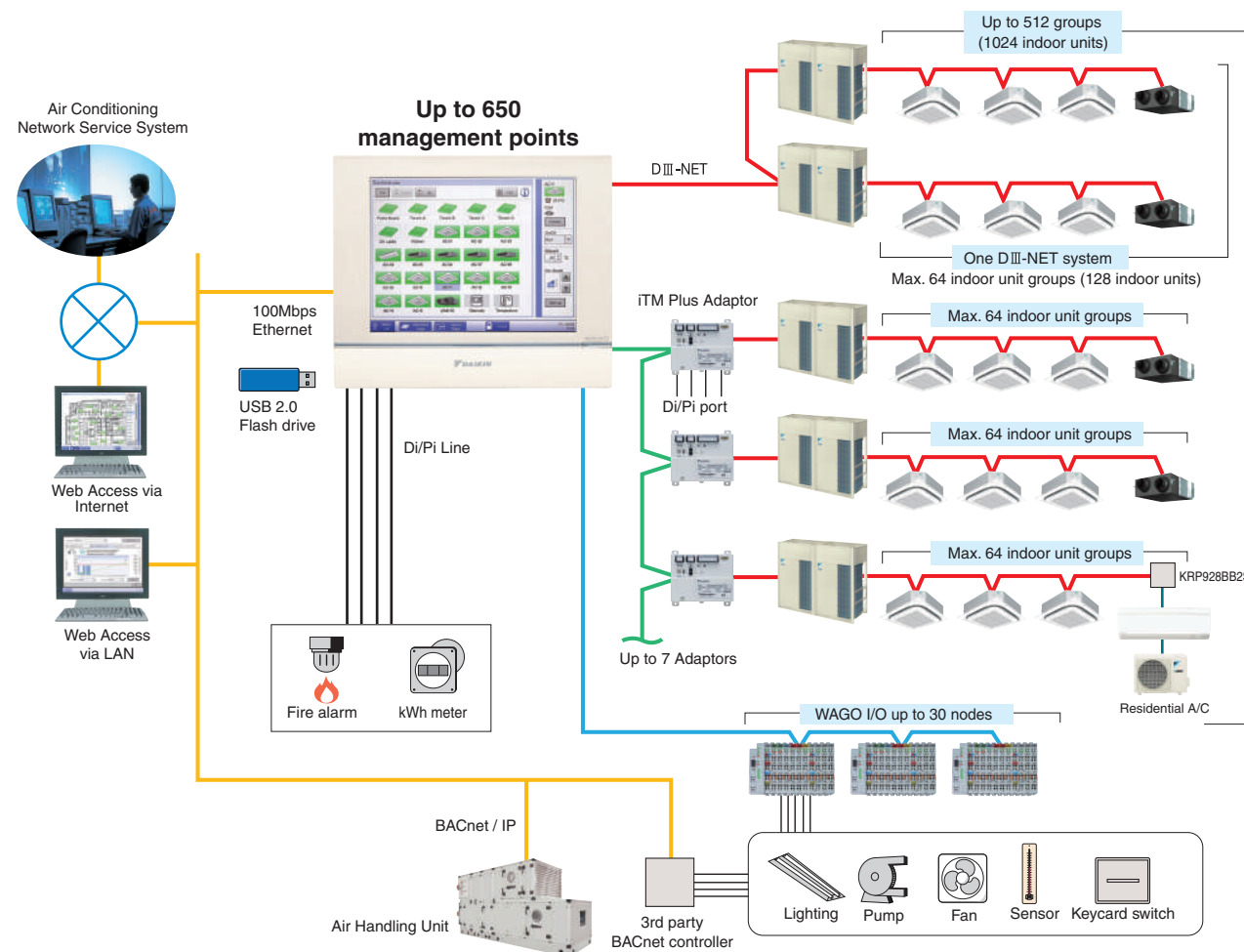

Features

Central control

- Handy area settings simplify detailed management of VRV system.
- Display of floor plans enables a quick search of desired air conditioning units.
- Operation history shows manner of control and origin in past operations of air conditioning units.

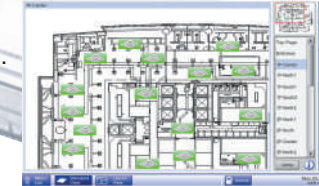

Remote access

- Remote access with a PC allows total air conditioning management using the same type of screens as those displayed in the intelligent Touch Manager.
- Authorised users can centrally control individual air conditioning units from their own computers.

Automatic control

- VRV systems are controlled automatically throughout the year by the schedule function.
- Interlocking VRV system and other equipment enables easy automation of building facilities operation.
- Setback adjusts temperature settings even when rooms are unoccupied.

Energy management

- The Energy Navigator feature simplifies energy management by tracking energy consumption data and identifying inefficient operation.



Troubleshooting

- Contact information of maintenance contractors can be registered and displayed.
- E-mails are sent automatically to alert of malfunctions and potential trouble.
- The intelligent Touch Manager can link to the Air Conditioning Network Service System for 24-hour monitoring of operating conditions and status.

Scalability

- A single intelligent Touch Manager can manage a small building or be expanded to handle medium- to large-sized buildings.

Connectivity

- BACnet connection with a wide range of building equipment.
- WAGO Ao and Pi are newly supported and connectable WAGO modules are added.

Advanced Control Systems

Intelligent Controller

Communication functions in the user-friendly icon-based multilingual controller simplify centralised control of the VRV system.

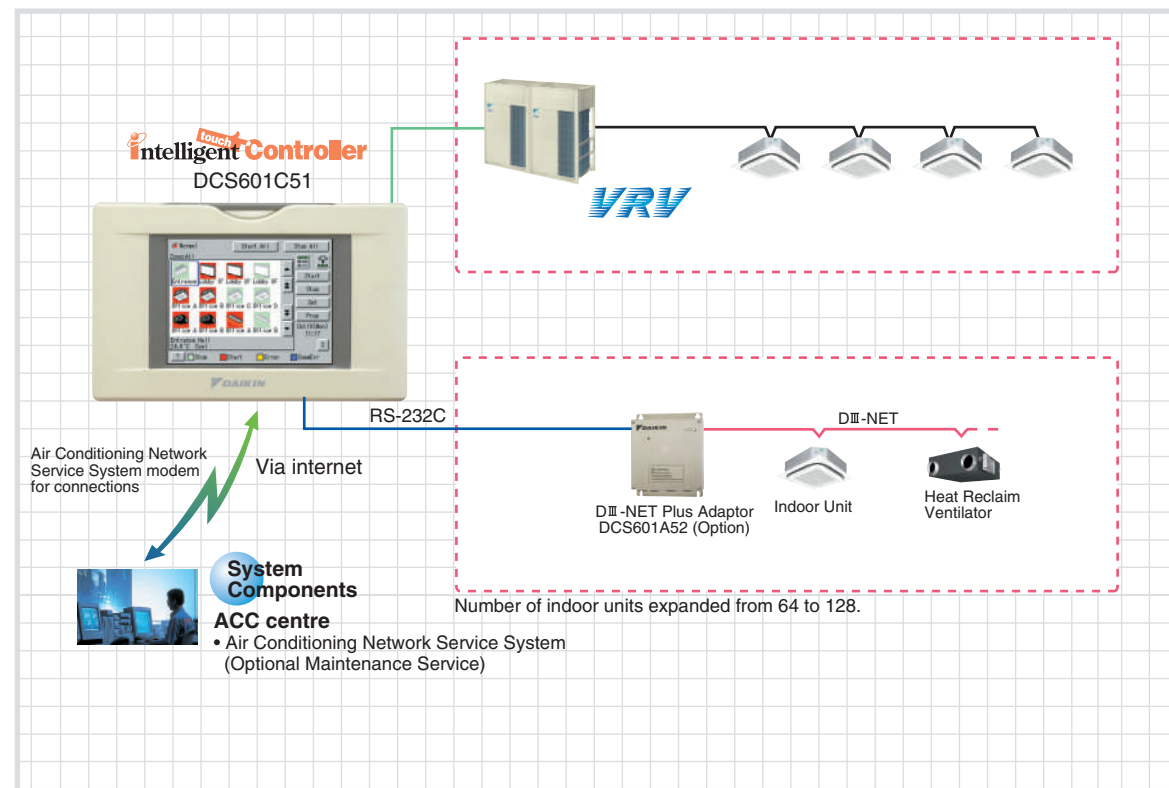

Features

- Colour LCD touch panel icon display
- Small manageable size
- Simplified engineering
- Multi language (English, French, Italian, German, Spanish, Dutch, Portuguese, Chinese and Korean)
- Yearly schedule
- Auto heat/cool change-over
- Temperature limitation
- Enhanced history function
- Built-in modem for connecting to Air Conditioning Network Service System (Option)
- Doubling of number of connectable indoor units by adding a DIII-NET Plus Adaptor (Option)



Interface for BACnet® and LONWORKS®

Integrated control systems that recognise the trend of open control systems

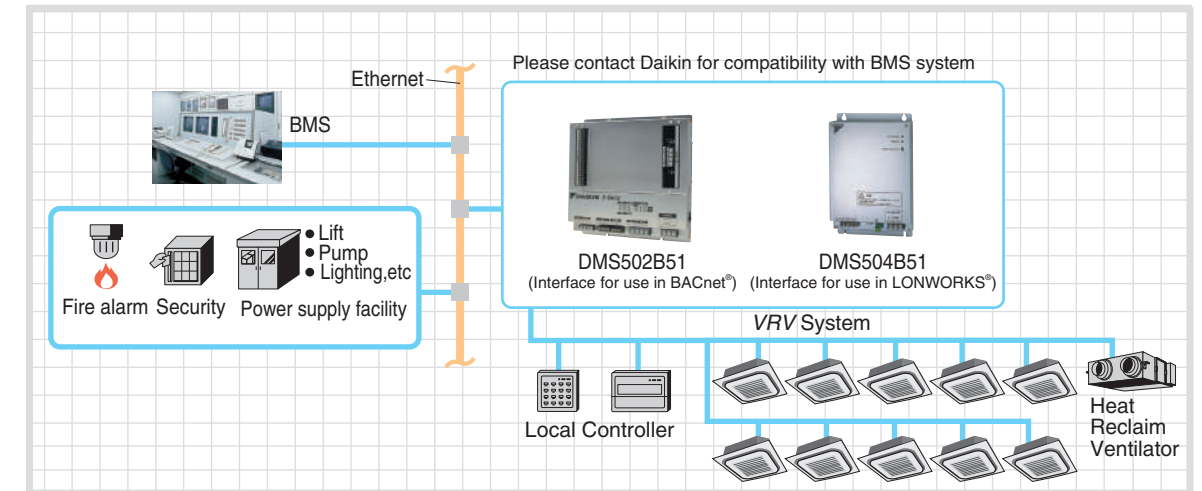

- Compatibility with BMS enhanced by utilising the international communication standards, BACnet® or LONWORKS®.

DMS502B51 Interface for use in BACnet®

- Support for Heat Reclaim Ventilator VAM series
- Selectable temperature unit
- BTL Certification
- PPD data (Optional Di board is required.)
- ISO 16484-5 (Does not support IEEE 802.3 protocol for BACnet®)
- Up to 40 outdoor units and 256 indoor unit groups on one gateway (optional adaptor)

DMS504B51 Interface for use in LONWORKS®

- XIF file for confirming of specifications of the units.
- Connectable up to 10 outdoor units and 64 indoor unit groups.

Air Conditioning Network Service System

Maintenance services that boost profits and customer satisfaction

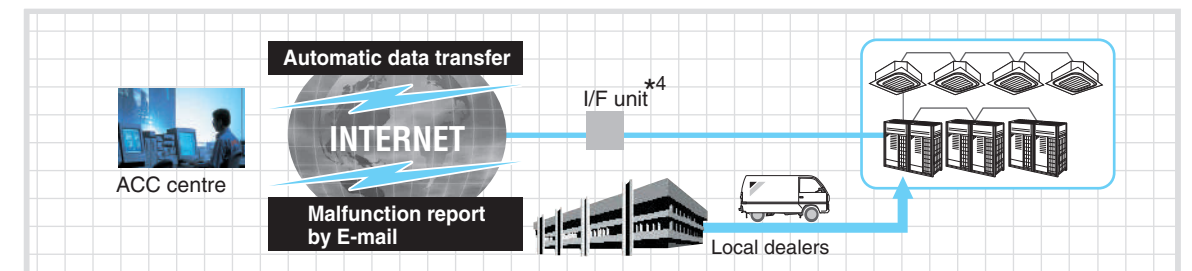

- 24 hour on-line diagnostic system
- Energy saving and extension of aircon operating life
- Maintenance management via A/C network service system reports
- Reliable service at shortest lead time

*1. Model name varies upon the system size.

*2. BACnet® is a registered trademark of American Society of Heating, Refrigerating and Air-Conditioning Engineers (ASHRAE).

*3. LonWorks® is a trademark of Echelon Corporation registered in the United States and other countries.

*4. For an I/F unit, one of the following can be selected: **Local Controller**, intelligent Touch Controller, or intelligent Touch Manager.

*5. Refer to the Options page for the name of each model.

Centralised Control Systems

- Up to 64 groups of indoor units (128 units) can be centrally controlled.
- Optional controllers for centralised control can be combined freely, and system can be designed in accordance with building scale and purpose.
- System integration with various air-conditioning peripheral equipment such as Heat Reclaim Ventilator is easy.
- Wiring can be run up to a total length of 2 km, and adapts easily to large-scale system expansion.

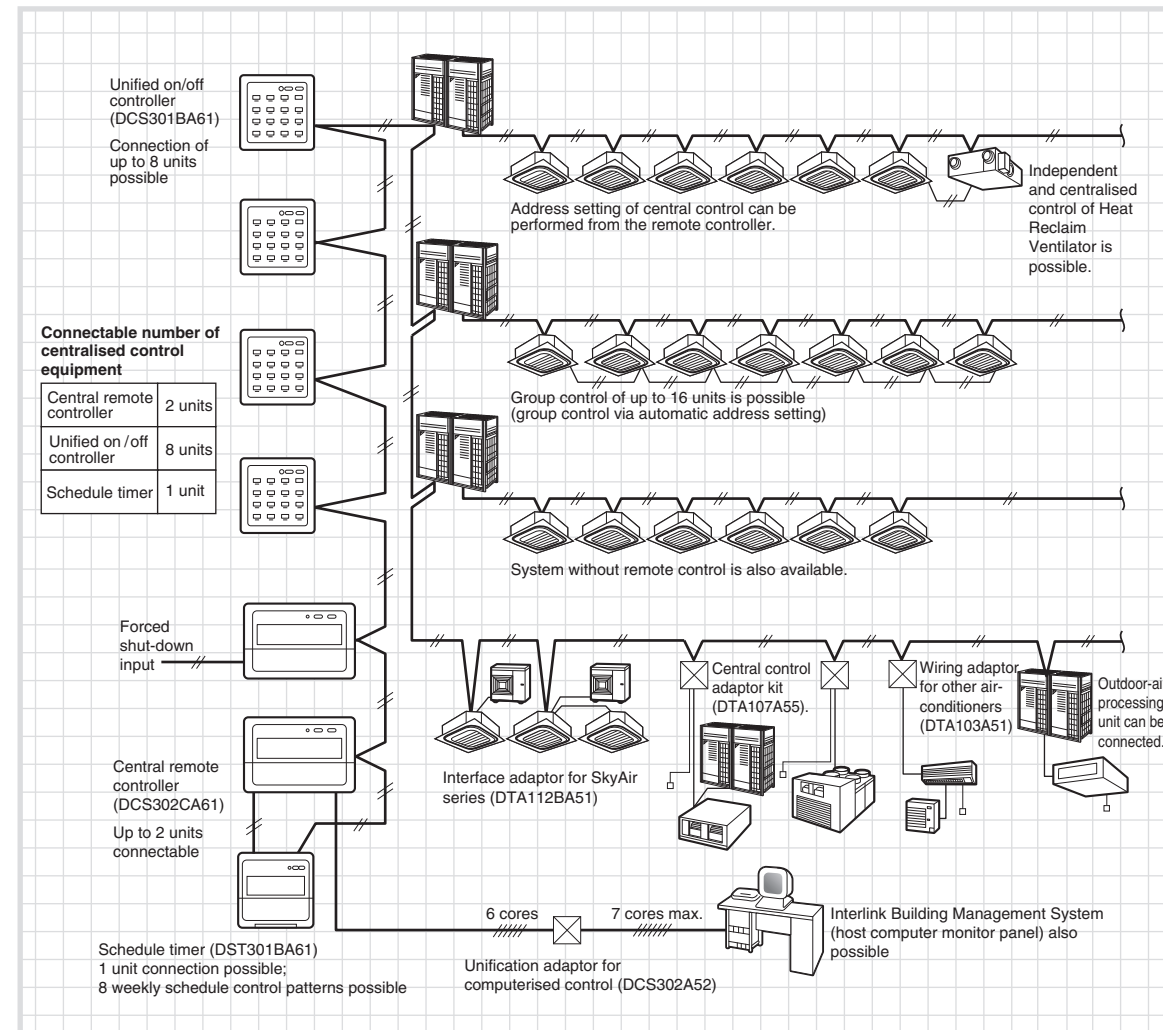

* Certain indoor units limit the functions of some control systems. For more details, please refer to the Engineering Data.

Residential central remote controller* (Option)



DCS303A51

Max. 16 groups of indoor units can be easily controlled with the large LCD panel.

- Max. 16 groups (128 indoor units) controllable
- Backlight and large LCD panel for easy readability
- ON/OFF, temperature settings and scheduling can be controlled individually for indoor units.
- All indoor units can be turned on or off at once with "ALL" button.
- Each group has a dedicated button for convenience.
- Outside temperature display

* For residential use only. Cannot be used with other centralised control equipment.

Central remote controller (Option)

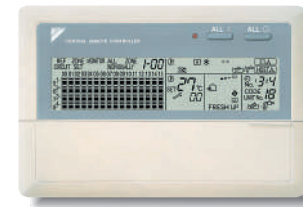

DCS302CA61

Max. 64 groups (zones) of indoor units can be controlled individually same as LCD Remote controller.

- Max. 64 groups (128 indoor units) controllable
- Max. 128 groups (128 indoor units) are controllable by using 2 central remote controllers, which can control from 2 different places.
- Zone control
- Malfunction code display
- Max. wiring length 1,000 m (Total: 2,000 m)
- Connectable with Unified ON/OFF controller, schedule timer and BMS system
- Airflow volume and direction can be controlled individually for indoor units in each group operation.
- Ventilation volume and mode can be controlled for Heat Reclaim Ventilator.
- Up to 4 ON/OFF pairs can be set per day by connecting a schedule timer.

Unified ON/OFF controller (Option)



DCS301BA61

Max. 16 groups of indoor units can be operated simultaneously/individually.

- Max. 16 groups (128 indoor units) controllable
- 2 remote controllers can be used to control from 2 different places.
- Operating status indication (Normal operation, Alarm)
- Centralised control indication
- Max. wiring length 1,000 m (Total: 2,000 m)
- Compact size casing (Thickness: 16 mm)
- Connectable with Central Remote controller, Schedule timer and BMS system

Schedule timer (Option)



DST301BA61

Max. 128 indoor units can be operated as programmed schedule.

- Max. 128 indoor units controllable
- When used in combination with a central remote controller, a maximum of 8 weekly schedule patterns can be set, while the central controller can be used to select desired zones. Up to 2 ON/OFF pairs can be set per day.
- Max. 48 hours back up power supply
- Max. wiring length 1,000 m (Total: 2,000 m)
- Compact size casing (Thickness: 16 mm)
- Connectable with Central Remote controller, Unified ON/OFF controller and BMS system

Heat Reclaim Ventilator — VAM Series

The Heat Reclaim Ventilator Creates a High-Quality Environment by Interlocking with the Air Conditioner

Model Names

VAM150GJVE, VAM250GJVE, VAM350GJVE, VAM500GJVE, VAM650GJVE, VAM800GJVE, VAM1000GJVE, VAM1500GJVE, VAM2000GJVE



Heat Reclaim Ventilator remote controller* BRC301B61 (Option)

* This remote controller is used in case of independent operation of Heat Reclaim Ventilator.

Improved Enthalpy Efficiency^{*1}
Higher External Static Pressure^{*2}
Enhanced Energy Saving Functions

This VAM series provides higher enthalpy efficiency^{*1}, due to the greatly enhanced performance of the thin film element. Furthermore, improved external static pressure^{*2} offers more flexibility for installation. Along with these three outstanding improvements, the nighttime free cooling operation contributes to energy conservation and more comfortable space.

^{*1} For models: VAM150/250/350/650/800/1000/2000GJVE

^{*2} For models: VAM150/350/500GJVE

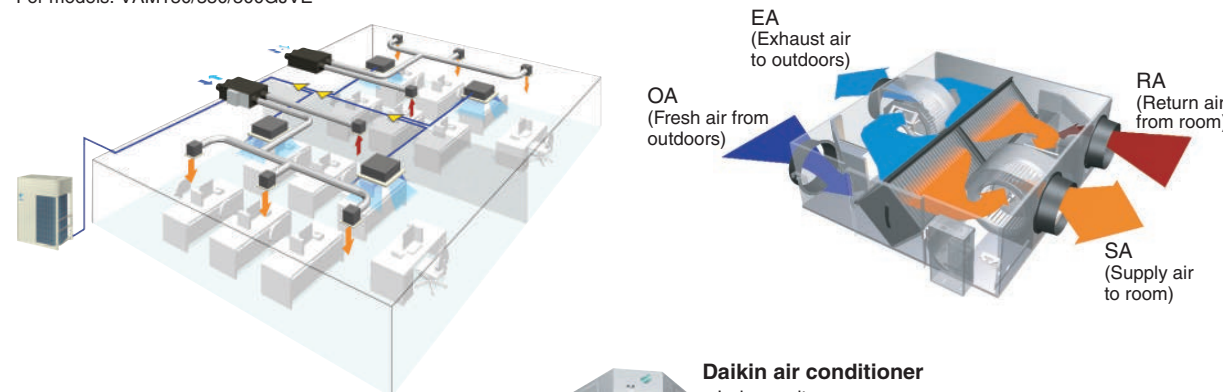

Intelligent Manager



LCD remote controller for indoor unit

- Operating mode signal
- Filter cleaning signal
- Failure detection signal

Interlocking

- ON/OFF signal
- Cooling/Heating mode signal
- Set temperature signal
- Ventilation signal



Heat Reclaim Ventilator

Compact Equipment

With a height of just 306 mm, the unit easily fits in limited spaces, such as above ceilings.

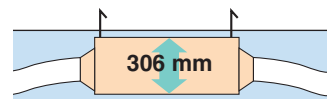

* For VAM500GJVE

Energy Conservation

Air conditioning load reduced by approximately 31%!

Cold Climate Compatible

Standard operation at temperatures down to -15°C.

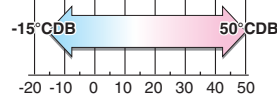

Air conditioning load reduced by approximately 31%!

Total heat exchange ventilation 23%

This unit recovers heat energy lost through ventilation and curbs room temperature changes caused by ventilation, thereby conserving energy and reducing the load on the air conditioning system.

Enthalpy efficiency drastically improved by employing thin film element! (VAM-GJ model)

Due to the thinner film...

- Decreases the moisture resistance of the partition sheets drastically.
- Realises more space for extra layers in the element, resulting in increased effective area that supply and exhaust air can be exposed to.

Moisture absorption increased by approx. 10%!

Thickness of the partition sheet
40 μm

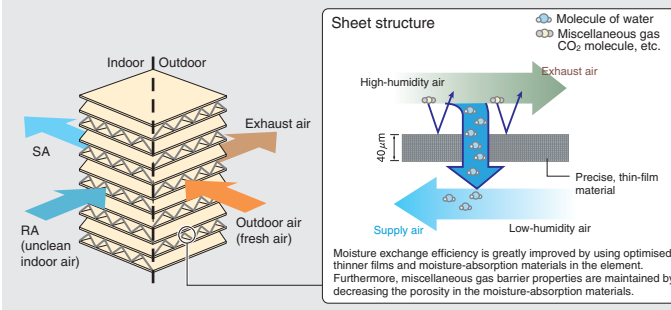

Auto-ventilation Mode Changeover Switching 6%

Automatically switches the ventilation mode (Total Heat Exchange Mode/Bypass Mode) according to the operating status of the air conditioner.

Pre-cool, Pre-heat Control 2%

Reduces air conditioning load by not running the Heat Reclaim Ventilator while air is still clean soon after the air conditioner is turned ON.

Air Conditioning Load Reduced by Approximately 31%

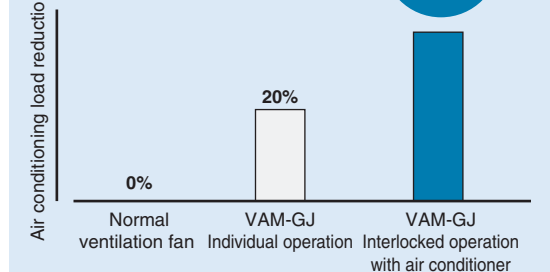

- The air conditioning load reduction values may vary according to weather and other environmental conditions at the location of the machine's installation.
- The air conditioning load reduction values are based on the following conditions; Application: Tokyo office building Building form: 6 floors above ground, 2 floors underground, floor area 2,100 m² Personnel density: 0.25 person/m² Ventilation volume: 25 m³/h Indoor air conditioning level: summer 25°C 50% RH, intermediate seasons 24°C 50% RH, winter 22°C 40% RH Operating time: 2745 hours (9 hours per day, approx. 25 days per month) Calculation method: simulation based on "MICRO-HASP/1982" of the Japan Building Mechanical and Electrical Engineers Association.

Nighttime free cooling operation^{*1}

Nighttime free cooling operation is an energy-conserving function that works at night when air conditioners are off. By ventilating rooms containing office equipment that raises the room temperature, nighttime free cooling operation reduces the cooling load when air conditioners are turned on in the morning. It also alleviates feelings of discomfort in the morning caused by heat accumulated during the night.

- Nighttime free cooling operation only works to cool and if connected to SkyAir or VRV systems.
- Nighttime free cooling operation is set to "off" in the factory settings, so if you wish to use it, request your dealer to turn it on.

^{*1} This function can be operated only when interlocked with air conditioners.

^{*2} Value is based on the following conditions:

- Cooling operation performed from April to October.
- Calculated for air conditioning sensible heat load only (latent heat load not included).

Air conditioning sensible heat load reduced by **approx. 5%^{*2}**

The indoor accumulated heat is discharged at night. This reduces the air conditioning load the next day thereby increasing efficiency.

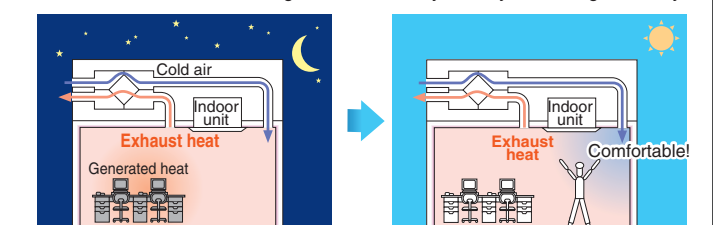

Heat is discharged.

The load is small so the temperature is rapidly reduced to a comfortable level.

* Interlocked operation with an air conditioner

Heat Reclaim Ventilator — VAM Series

CO₂ Sensor Optional Kit Connection

The CO₂ sensor controls airflow so that it best matches the changes in CO₂ level. This prevents energy losses from over-ventilation while maintaining indoor air quality with optional CO₂ sensor.

Example of CO₂ sensor operation in an office room:

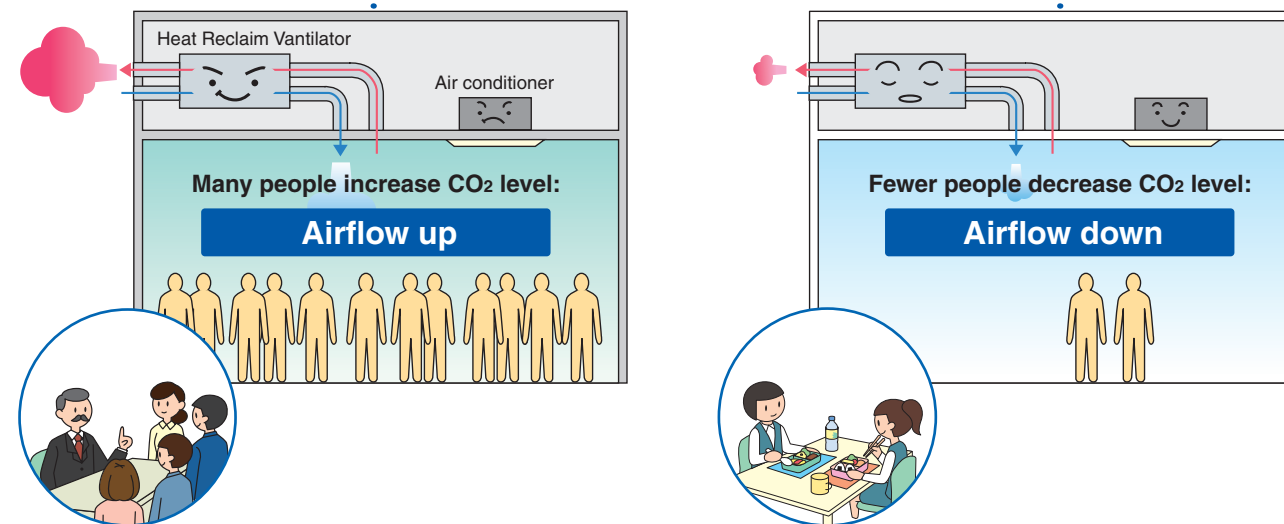
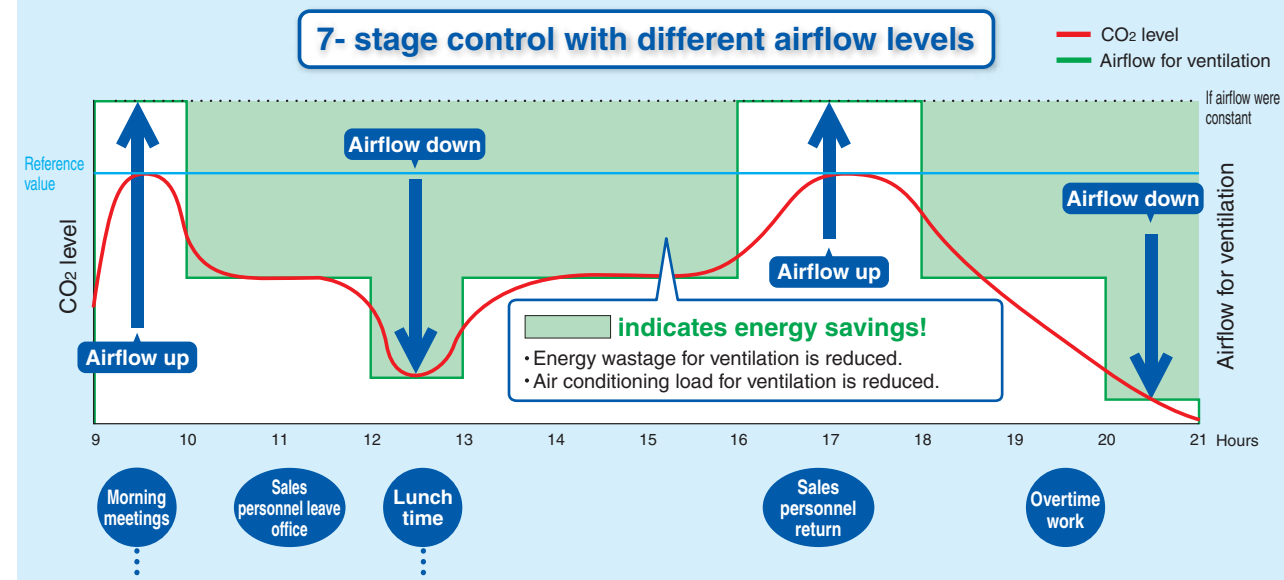

Specifications

Models		VAM150GJVE	VAM250GJVE	VAM350GJVE	VAM500GJVE	VAM650GJVE	VAM800GJVE	VAM1000GJVE	VAM1500GJVE	VAM2000GJVE						
Power Supply		1-phase, 220-240 V/ 220 V, 50 Hz/ 60 Hz														
Temp. Exchange Efficiency (%)	Ultra-High	79	75	79	74	75	72	78	72	77						
	High	79	75	79	74	75	72	78	72	77						
	Low	85	79	82	80.5	77.5	74.5	81	76	81						
Enthalpy Exchange Efficiency (%)	For Heating	Ultra-High	72	71	70	67	67.5	65	70	65	72					
		High	72	71	70	67	67.5	65	70	65	72					
		Low	76.5	74	77	74.5	72	68	73	67.5	76					
	For Cooling	Ultra-High	66	63	66	55	61	61	64	61	62					
		High	66	63	66	55	61	61	64	61	62					
		Low	70.5	66	70	59.5	64.5	64.5	69	64.5	67					
Power Consumption	Heat Exchange Mode	Ultra-High	134	141	226	270	398	680	760	1,300	1,542					
		High	117	125	211	217	332	597	648	1,144	1,315					
		Low	58	59	120	136	207	483	512	927	1,039					
	Bypass Mode	Ultra-High	134	141	226	270	398	680	760	1,300	1,542					
		High	117	125	211	217	332	597	648	1,144	1,315					
		Low	58	59	120	136	207	483	512	927	1,039					
Sound Level dB(A)	Heat Exchange Mode	Ultra-High	28.5	29	33	34	36	39.5	39.5	41.5	42					
		High	27.5	28	30	32	34	37.5	37.5	39.5	40					
		Low	21	21	23	24	28	34	34.5	36	39					
	Bypass Mode	Ultra-High	29.5	30.5	34.5	35.5	37.5	41	40.5	42.5	44					
		High	28.5	29.5	31.5	33.5	35.5	39	38.5	41.5	42					
		Low	22	22.5	24.5	25.5	29.5	35.5	35.5	37.5	41					
Casing		Galvanised steel plate														
Insulation Material		Self-extinguishable polyurethane foam														
Dimensions (HxWxD)	mm	278x810x551			306x879x800		338x973x832		387x1,111x1,214		785x1,619x832		785x1,619x1,214			
Machine Weight	kg	24			32		45		55		67		129		157	
Heat Exchange System		Air to air cross flow total heat (Sensible heat + latent heat) exchange														
Heat Exchange Element Material		Specially processed nonflammable paper														
Air Filter		Multidirectional fibrous fleeces														
Fan	Type	Sirocco fan														
	Airflow Rate (m ³ /h)	Ultra-High	150	250	350	500	650	800	1,000	1,500	2,000					
		High	150	250	350	500	650	800	1,000	1,500	2,000					
		Low	95	155	230	295	470	670	840	1,260	1,580					
	External Static Pressure (Pa)	Ultra-High	154	96	222	150	125	170	192	150	140					
		High	131	65	145	52	67	85	86	72	32					
Low		60	20	30	18	38	61	60	50	45						
Motor Output	kW	0.030x2			0.090x2		0.140x2		0.280x2		0.280x4					
Connection Duct Diameter	mm	φ100			φ150		φ200		φ250		φ350					
Unit ambient condition		-15°C-50°CDB, 80%RH or less														

- Notes:
1. Sound level is measured at 1.5 m below the centre of the body.
 2. Airflow rate can be changed over to Low mode or High mode.
 3. Sound level is measured in an anechoic chamber.
 4. Sound level generally becomes greater than this value depending on the operating conditions, reflected sound, and peripheral noise.
 5. The sound level at the air discharge port is about 8 dB(A) higher than the unit's sound level.
 6. The specifications, designs and information given here are subject to change without notice.
 7. Efficiency is measured under the following conditions:
Ratio of rated external static pressure has been maintained as follows; outdoor side to indoor side = 7 to 1.
 8. In conformance with JIS standards (JIS B 8628), operating sound level is based on the value when one unit is operated, with the value converted for an anechoic chamber. This is transmission sound from the main unit, and does not include sound from the discharge grille. Thus it is normal for the sound to be louder than the indicated value when the unit is actually installed.
 9. Sound level from the discharge port causes the value to be approximately 8 dB(A) (models with the airflow rate of less than 150 to 500 m³/h) to approximately 11 dB(A) (models with the airflow rate of 650 m³/h or more) greater than the indicated value. Furthermore, fan rotation and noise from the discharge grille may increase depending on the on-site duct resistance conditions. Please consider noise countermeasures when installing the unit.
 10. With large models in particular (1500 and 2000 m³/h models), if the supply air (SA) grille is installed near the main unit, the noise of the main unit may be heard from the discharge grille via the duct, and this will result in a marked increase in noise. In such cases, if peripheral effects are included (such as reverberation of the floor and walls, combination with other equipment, and background noise), sound level may be as much as 15 dB(A) higher than the indicated value. When installing a large model, please provide as much separation as possible between the main unit and the discharge grille. If the equipment and discharge grille are near each other, please consider countermeasures such as the following:
• Use a sound-muffling box, flexible duct and sound-muffling air supply/discharge grilles
• Decentralised installation of discharge grilles
 11. When installing in a location with particularly low background noise such as a classroom, please consider the following measures to avoid transmission sound from the main unit:
• Use of ceiling materials with high sound insulating properties (high transmission loss)
• Methods of blocking sound transmission, for example, by adding sound insulating materials around the bottom of the sound source.
Alternatively, consider supplementary methods such as installing the equipment in a different location (corridor, etc.)

Options

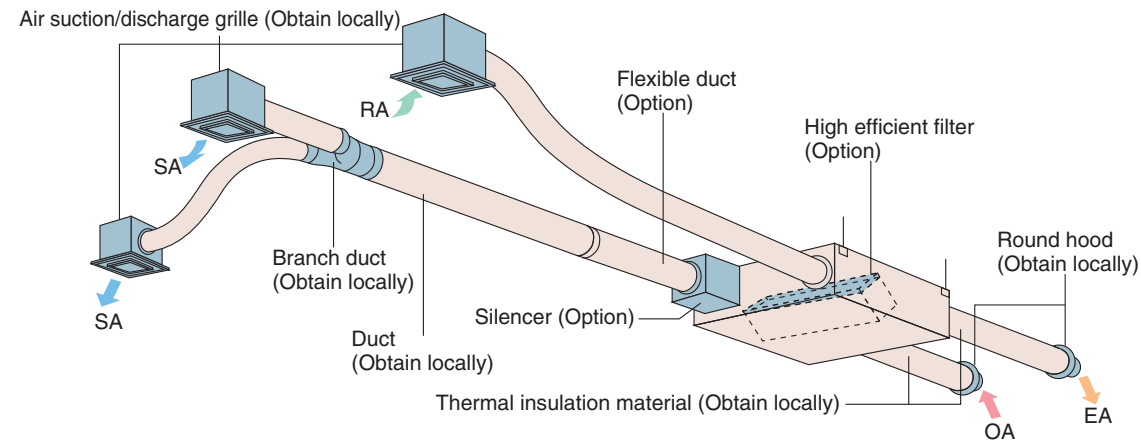

Option List

Item	Applicable model	VAM150 · 250 · 350 · 500 · 650 · 800 · 1000 · 1500 · 2000GJVE												
Controlling device	Heat Reclaim Ventilator remote controller	BRC301B61												
	Centralised controlling device	Residential central remote controller	DCS303A51 *1											
		Central remote controller	DCS302CA61											
		Unified ON/OFF controller	DCS301BA61											
		Schedule timer	DST301BA61											
PC Board Adaptor	Wiring adaptor for electrical appendices	KRP2A61												
	For humidifier	KRP50-2												
	Installation box for adaptor PCB	KRP50-2A90 (Mounted electric component assy of Heat Reclaim Ventilator)												
	For heater control kit	BRP4A50												
	For wiring	Type (indoor unit of VRV)	FXFSQ-A	FXFQ-A	FXZQ-M	FXCQ-M	FXEQ-A	FXDQ-PB FXDQ-NB	FXMQ-A FXMQ-P	FXMQ-MA	FXUQ-A	FXHQ-MA	FXAQ-P	FXLQ-MA FXNQ-MA
		Installation box for adaptor PCB ☆	—	—	KRP1BA57 * KRP1BA101	KRP1B61 * KRP1B96	—	KRP1B56 * KRP1BA101	KRP1C64 * KRP4A96	KRP1B61	—	KRP1BA54 KRP1CA93	—	KRP1B61

Notes: 1. Installation box* is necessary for each adaptor marked *.
 2. Up to 2 adaptors can be fixed for each installation box.
 3. Only one installation box can be installed for each indoor unit.
 4. Up to 2 installation boxes can be installed for each indoor unit.
 5. Installation box* is necessary for second adaptor.
 6. Installation box* is necessary for each adaptor.
 7. *1 For residential use only. When connected with Heat Reclaim Ventilator (VAM), you can only switch the power ON/OFF. Cannot be used with other centralised control equipment.

Item	Type	VAM150GJVE	VAM250GJVE	VAM350GJVE	VAM500GJVE	VAM650GJVE	VAM800GJVE	VAM1000GJVE	VAM1500GJVE	VAM2000GJVE
Additional function	Silencer	—	—	—	KDDM24B50	—	KDDM24B100	—	—	KDDM24B100x2
	Nominal pipe diameter [mm]	—	—	—	φ200	—	—	—	—	φ250
	High efficiency filter	KAF242H25M	—	KAF242H50M	—	KAF242H65M	KAF242H80M	KAF242H100M	KAF242H80Mx2	KAF242H100Mx2
Air filter for replacement	KAF241G25M	—	KAF241G50M	—	KAF241G65M	KAF241G80M	KAF241G100M	KAF241G80Mx2	KAF241G100Mx2	
Flexible duct (1 m)	K-FDS101D	K-FDS151D	—	K-FDS201D	—	—	—	K-FDS251D	—	—
Flexible duct (2 m)	K-FDS102D	K-FDS152D	—	K-FDS202D	—	—	—	K-FDS252D	—	—
Duct adaptor	Nominal pipe diameter [mm]	—	—	—	—	—	—	—	YDFA25A1	—
CO ₂ sensor	—	—	—	BRYMA65	—	BRYMA100	—	BRYMA65	BRYMA100	—

PCB adaptor for heater control kit (BRP4A50)

When the installation of an electric heater is required in a cold region, this adaptor with an internal timer function eliminates the complicated timer connecting work that was necessary with conventional heaters.

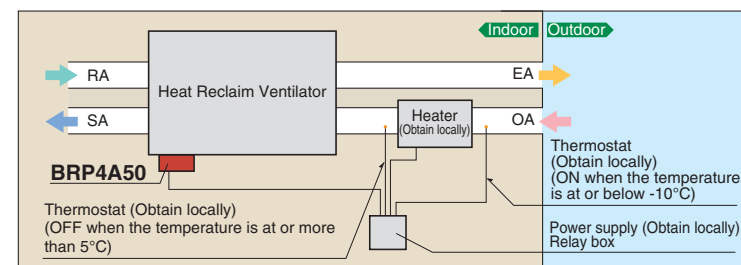

Notes when installing

- Examine fully an installation place and specification for using the electric heater based on the standard and regulation of each country.
- Supply the electric heater and safety production devices such as a relay and a thermostat, etc of which qualities satisfy the standard and regulation of each country at site.
- Use a non-inflammable connecting duct to the electric heater. Be sure to allow 2 m or more between the electric heater and Heat Reclaim Ventilator for safety.
- For the Heat Reclaim Ventilator, use a different power supply from that of the electric heater and install a circuit breaker for each.

MEMO